

Offices
Leisure Centres
Schools
Theatres
Stadia
Museums
Railway Stations



Factories
Airports
Corporate HQ
Arenas
Conference Centres
Ferries
Cruise Ships
Hotels
Magistrates Courts
MOD
Call Centres
Multi Building Sites
Retail
County Courts
Shopping Centres

The MSL1000—Latching Monitored Serial Link Interface

- The interface is designed to provide D.C. monitoring of up to 8/16 alarm contact pairs.
- Contains 3 cards, a Volt free contact interface, and RS485 communications card.
- The HI and LO threshold levels are programmed with jumper links at two alternative levels to allow monitoring of NO or NC alarm contacts.
- Two fault conditions may be detected; open circuit when the monitored voltage exceeds 5/6 of the reference level and short-circuit when the monitored voltage falls below 1/6 of the reference level.

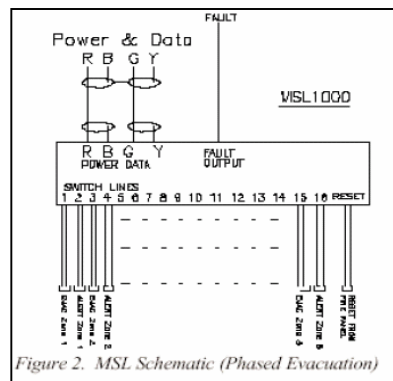
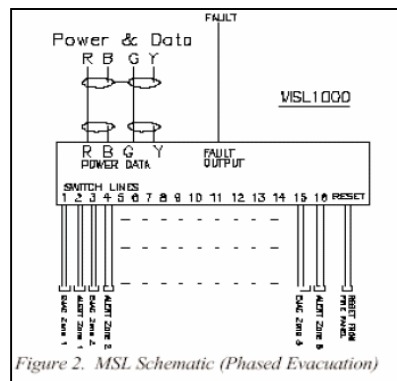

MSL1000

Fire Panel Interface

The **MSL1000** is linked to the Master Fault Monitoring System (FMS) which will report any problems with the system.

The detector is designed to signal a fault condition to the FMS if power to the unit is lost.

The output connections of the interface are linked to the serial 485 interface card and housed into a single 19" rack mountable, 1U chassis.

This connects the Audix Alpha audio processor, which contains the emergency message cards. The data between the MSL1000 and Alpha is fault monitored and data errors are reported to the master FMS.

Whenever the fire alarm contact activates, the MSL1000 will send data to the Audix Alpha audio processor and trigger the emergency fire message.

Messages are stored as raw data files and not as simple tone generators, so any voice and/or alarm message can be recorded and stored on the message cards.

- The fire panel should maintain the contact for the duration of the alarm condition.
- Whenever an output from the Fire Panel is switched to the non alarm state, the reset output must be pulsed for 2 seconds.

MSL1000

Fire Panel Interface

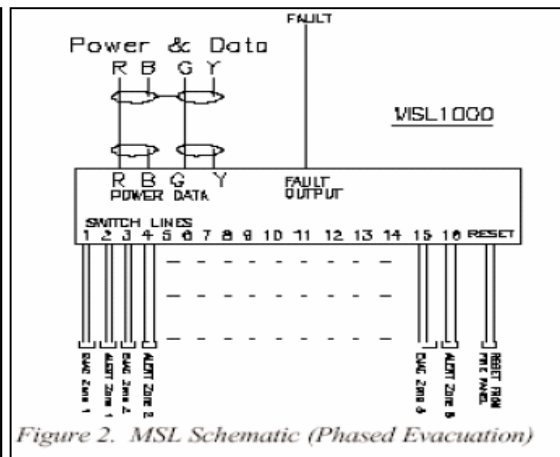
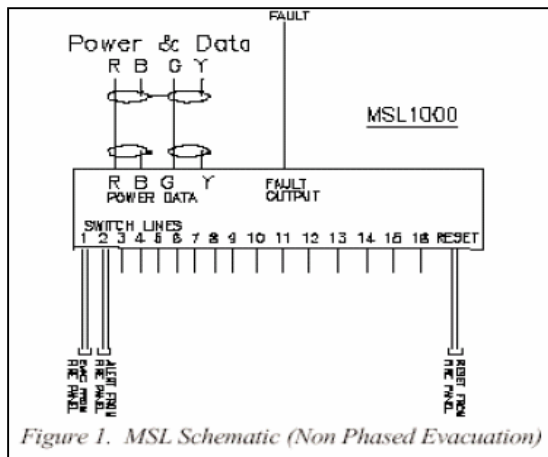

Audix Systems reserves the right to modify or withdraw any product or service without notice