

Standby Battery System SBS241

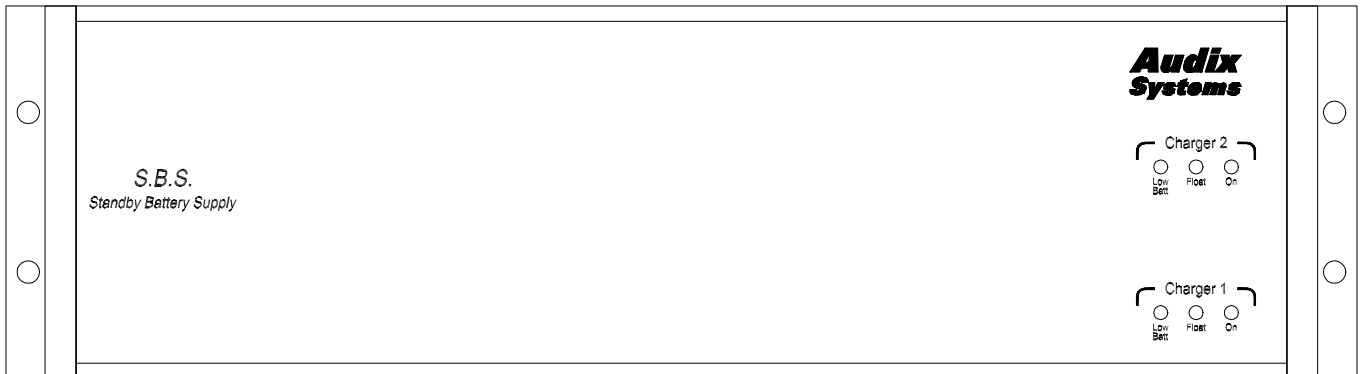

Warning!

- **Only a qualified and trained electrical/electronics engineer should be permitted to work on this product**
- **Before commencing the installation of the batteries into an SBS unit, please read the following instructions carefully.**
- **There are a number of different SBS versions, make sure that these instructions are used on the correct SBS type.**

The Batteries supplied with the SBS unit contain charge and therefore present a high risk from shorting. Although the battery chassis is isolated from the battery circuit great care must be taken not to short out the batteries. Shorting may occur if unconnected cables or metal tools touch the chassis and the battery terminals

Please read the Safety Considerations section.

Audix Systems
Station Road
Wenden
Saffron Walden
CB11 4LG
Tel 01799 540888
Fax 01799 541618

SBS241 Battery Installation Manual

Installation Instructions

1. Top view

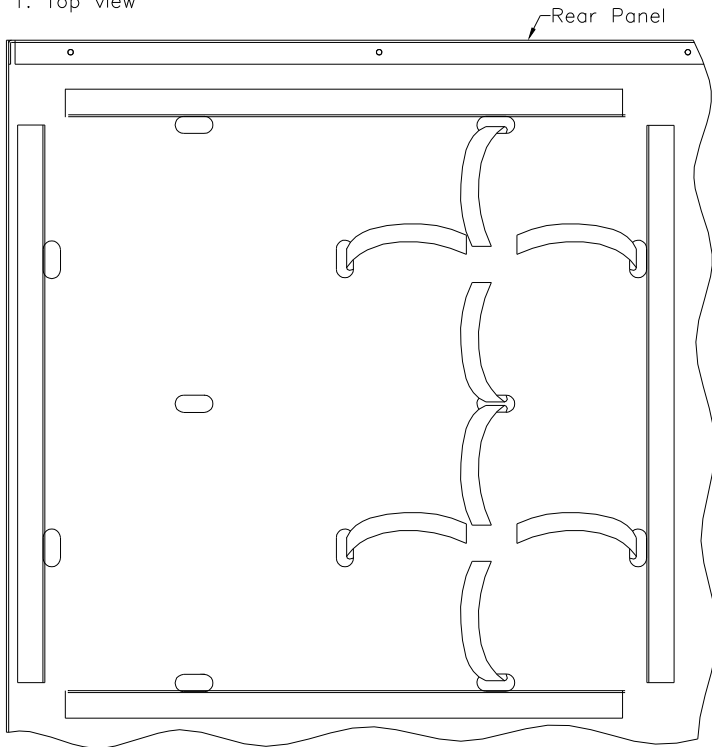

SBS241 Battery strap positions

Fitting Straps

Feed straps supplied from the underside of the battery chassis through the slots provided.

2. Top view

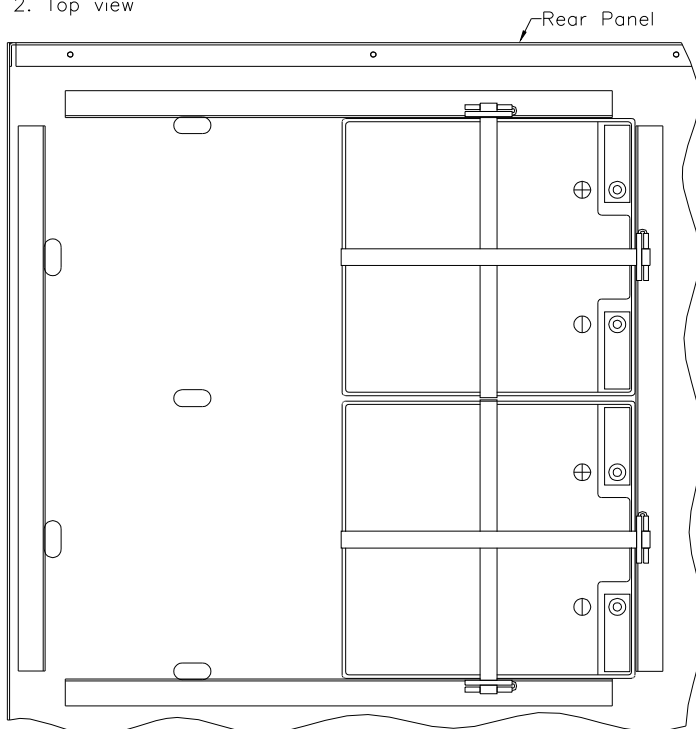

SBS241 Batteries strapped into position

Fitting Batteries and Buckles

With the straps moved clear of the pending battery location, carefully lower each battery into position. Each buckle should be positioned on the outside edge of the battery as shown.

SBS241 Battery Installation Manual

3.

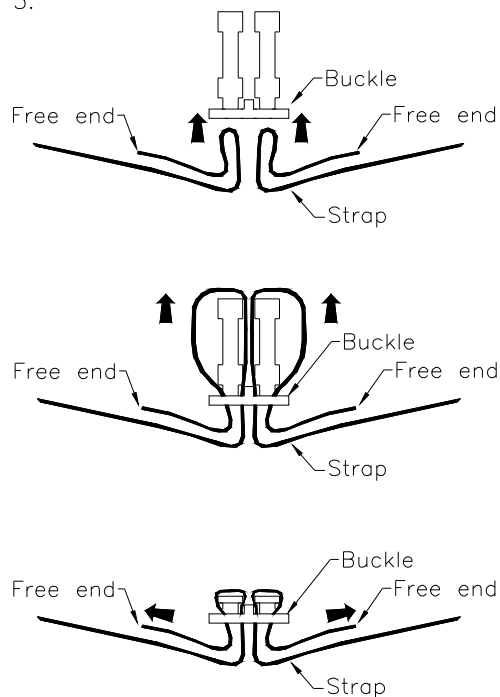

Assembling Straps and Buckles

1. Form a loop at each end of the strap, then pass loops through the slots in the buckle.
2. With both loops extended above the buckle by approximately 30mm fold the tags down into the centre of the loops.
3. Now simultaneously pull the free ends of strap to hold the battery into position.

Repeat with each strap.

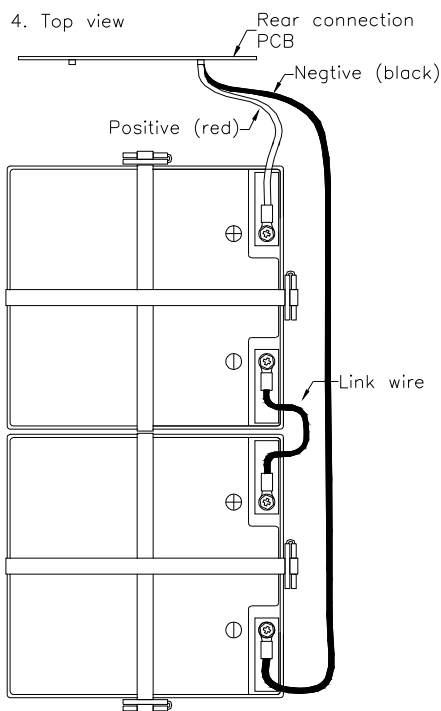

SBS241 Battery wiring layout

Wiring Detail

1. Connect red cables from the rear connection PCB to battery positive. Fix with screw and spring washer provided.
2. Connect black cables from the rear connection PCB to battery negative as shown. Fix with screw and spring washer provided.
3. With all other connections completed fit link cable as shown. Fix with screws and spring washers provided.

Tools

Either 8mm ring spanners or No. 2 pozi-drive screwdriver should be used.

Fitting Plastic Cover

1. The cover is to be slid across the top of the batteries and located under the lip of the rear panel. Note that the cover only fits correctly one way round!
2. The front edge of the cover is now to be carefully inserted into the extruded slot on the rear of the front panel.

SBS241 Battery Installation Manual

Fitting Fuses

Fit the four 25A fuses provided to fuse sockets on battery pack rear panel. Note these fuses protect the cable and equipment connected to the battery. Smaller fusing may be required to provide the correct protection of connected devices.

SAFETY CONSIDERATIONS

Only a qualified and trained electrical/electronics engineer should be permitted to work on this product

Chemical - Risk

In the case of leakage, damage or rupturing of the sealed lead acid battery casing, there is a high risk of exposure to the electrolyte jelly contained within. The electrolyte based on sulphuric acid and therefore is toxic and corrosive!

Electrolyte Exposure

If the exposure to electrolyte results in contact with the skin or eyes:

IMMEDIATELY FLUSH WITH COPIOUS AMOUNTS OF WATER.

With eye contact continue to flush with water for 15 minutes and consult a doctor.

Electrical Safety

Having a low internal resistance, sealed lead-acid batteries can provide exceptionally high currents. Great care must be taken to prevent shorting of terminals or wiring.

HIGH DC CURRENTS ARE DANGEROUS

BATTERIES MAY EXPLODE IF SHORTED

Lifting - Risk

With batteries installed the SBS range of battery units are **VERY HEAVY** and can weigh up to 44kilos. Lifting aids should be used.

AVOID MANUAL HANDLING IF YOU BELIEVE THERE IS A RISK OF INJURY.

DISCLAIMER

This manual contains information that is correct to the best of Audix Systems knowledge. It is intended to be a guide and should be used as such. It should not be considered as a sole source of technical instruction, replacing good technical judgement, since all possible situations cannot be anticipated. If there are any doubts as to exact installation, configuration and/or use, call Audix Systems on +44 (0)1799 540888

ACKNOWLEDGEMENTS

All trademarks are recognised
© Copyright Audix Systems 2005