

CB200

1-8 Zone Conventional Control Panels



Key Features

- ◆ Built-in detector removal indication facility
- ◆ From 1 to 8 zones
- ◆ 4 Alarm circuits on 4-8 zone panels
- ◆ Conforms to the requirements of EN54-2
- ◆ User-friendly access code
- ◆ One-man test facility
- ◆ Non-latching zone feature
- ◆ Class change input
- ◆ Earth fault monitoring
- ◆ Fully-functional repeater available (4 & 8 zone panels only)
- ◆ Removable cable-entry grommets
- ◆ User-friendly controls
- ◆ Surface or semi-flush mounting as standard
- ◆ Ample termination space
- ◆ Flame-resistant polycarbonate enclosure
- ◆ Log book and manual supplied
- ◆ Complies with EMC and LVD directives

Introduction

The CB200 conventional panel may be supplied in 1, 2, 4 or 8 zone formats. It complies with the requirements of EN54 Part 2. All zones and alarm circuits are monitored for open and short circuit fault conditions with detector removal facility also provided as standard.

The cabinet will house 2 x 12V 2.1AH S.L.A. batteries wired in series, which will sustain an 8 zone panel for up to 24 hours. All panels have a zone 1 non-latch facility to enable panel interlinking without "lock-up" occurring. The class change input enables the alarm circuits to operate without panel indication or panel latching.

The cabinet back-box houses only the transformer, thus providing a virtually empty enclosure for first fix installation. A steel gland plate, removable plastic grommets and ample space are designed to assist with cable termination. A slide-in insert is included for clear zone identification. The surface-mount electronics motherboard is fitted and terminated after first fix installation. Finally a terminal cover completes the panel installation.

The 4 & 8 zone panels will accommodate up to 3 repeater panels, which are connected by a shielded 2- core data cable where the repeater panels are powered locally, or an additional 2-core may be run from the panel for power (Max. 1 repeater may be powered from the panel).

From the UK's leading control panel manufacturer



Assessed to ISO 9001: 2000
Certificate number 018



INVESTOR IN PEOPLE

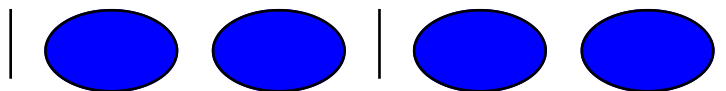

Typical Connections

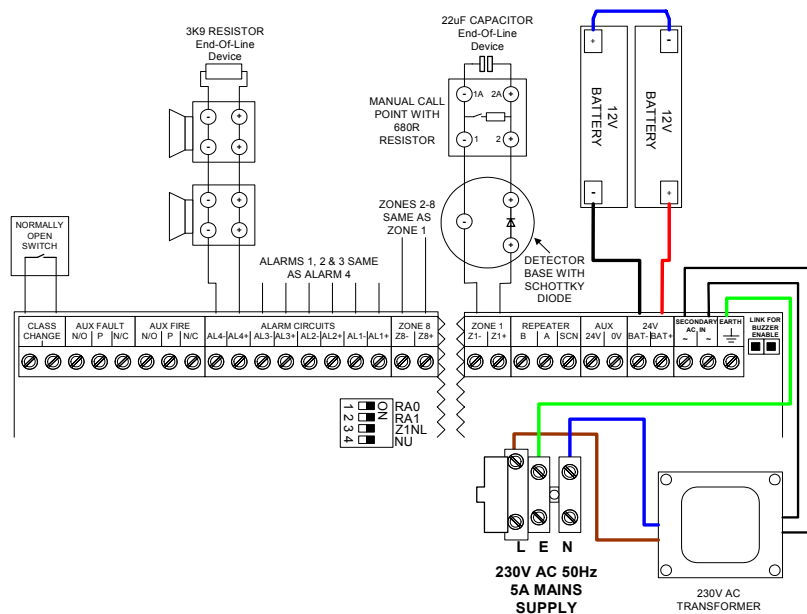

Technical Specifications

	1 zone panel	2 zone panel	4 zone panel	8 zone panel
Maximum field equipment load:	800mA			
Auxiliary 24VDC output	250mA			
Mains failed current consumption:	35mA @24VDC	40mA @24VDC	40mA @24VDC	40mA @24VDC
Maximum battery charger output:	500mA @27.5 VDC			
Common fire output:	Volt-free contacts - 1A, 30V DC max.			
Common fault output:	Volt-free contacts - 1A, 30V DC max.			
Alarm circuit output:	2 at 250mA each @28VDC	4at 500mA each @28VDC	4at 500mA each @28VDC	4at 500mA each @28VDC
Battery size:	2 x 12V 2.1AH sealed lead acid	2 x 12V 2.1AH sealed lead acid	2 x 12V 2.1AH sealed lead acid	2 x 12V 2.1AH sealed lead acid
Cabinet Sizes (Back box only)	245mmH x 287mmW x 66mmD (Excluding front cover)			
Weight (excluding batteries):	2.3kg	2.3kg	2.3kg	2.3kg

Note: On the 4-8 zone panels the total current available for the field devices is 800mA at 24VDC. This current must be shared between the alarm and aux. supply.

Part Numbers

2500/383	CB200 1 zone control panel
2500/384	CB200 2 zone control panel
2500/385	CB200 4 zone control panel
2500/386	CB200 8 zone control panel
2500/967	CB200 Repeater c/w PSU
2500/968	CB200 Repeater— Panel Powered

From the UK's leading control panel manufacturer

Control Equipment Ltd, Hillcrest Business Park, Cinderbank, Dudley, West Midlands, DY2 9AP, United Kingdom

Phone: +44 (0)1384 458651 Fax: +44 (0)1384 458972

cb200SL/rev6/10.04