

Control Equipment Limited
Precept^{en} Output Expansion Module
Application Guide

Contents

1	GENERAL DESCRIPTION.....	3
2	GENERAL FEATURES:.....	3
3	OUTPUT MODULES – SPECIFIC FEATURES	4
3.1	C1633 – 8 WAY OPEN COLLECTOR [TYPE 1 – INDICATION] MODULE.....	4
3.2	C1634 – 8 WAY VOLT-FREE RELAY [TYPE 2 FIRE PROTECTION] OUTPUT MODULE	5
3.3	C1635 – 8-WAY MONITORED/POWERED RELAY [TYPE 2 FIRE PROTECTION OR TYPE 3 ALARM] OUTPUT MODULE.....	6
	C1630 OUTPUT INTERFACE	7
4	OUTPUT MODULE ENCLOSURES.....	7
4.1	PRECEPT ^{EN} 8/16 EXPANSION OPTIONS	7
4.2	PRECEPT ^{EN} 32 EXPANSION OPTIONS	8
4.3	DEDICATED OUTPUT EXPANSION ENCLOSURES	8
5	ORDERING INFORMATION.....	10
6	FIELD WIRING CONNECTIONS.....	11
7	MECHANICAL, ELECTRICAL & ENVIRONMENTAL SPECIFICATION FOR EXPANDED PANELS.....	12
8	EXPANSION MODULE – I/O SPECIFICATION	14

List of Tables

TABLE 1 - MAX QTY OF O/P MODULES SUPPORTED BY EACH PANEL.....	3
TABLE 2 – MAINS INPUT SPECIFICATION.....	12
TABLE 3 - POWER SUPPLY UNIT OUTPUT SPECIFICATION	12
TABLE 4 - BATTERY SPECIFICATION.....	13
TABLE 5 - EXPANSION MODULE SIGNALLING O/P SPECIFICATION	14
TABLE 6 - EXPANSION MODULE 24V AUXILIARY SUPPLY O/P SPECIFICATION	14
TABLE 7 - EXPANSION MODULE INPUT SPECIFICATION	14
TABLE 8 - EXPANSION MODULE POWER CONSUMPTION SPECIFICATION.....	14
TABLE 9 – OUTPUT EXPANSION PANELS – MODULE ACCOMMODATION, PSU OPTIONS AND MECHANICAL DETAILS.....	15

List of Figures

FIGURE 1 – C1633 PCB LAYOUT.....	4
FIGURE 2 - C1634 PCB LAYOUT.....	5
FIGURE 3 - C1635 PCB LAYOUT.....	6
FIGURE 4 – C1630 PCB LAYOUT.....	7
FIGURE 5– PRECEPT ^{EN} 8/16 [WITH SINGLE IO BOARD FITTED INTERNALLY] –INTERNAL VIEW	7
FIGURE 6 – PRECEPT ^{EN} 16 EXP [32 ZONE ENCLOSURE WITH TWO IO BOARDS] – INTERNAL VIEW	8
FIGURE 7 – PRECEPT ^{EN} 5-WAY EXPANSION BOARD ENCLOSURE – EXTERNAL VIEW	9
FIGURE 8 – PRECEPT ^{EN} EXP 5 [5-WAY EXPANSION BOARD ENCLOSURE WITH SPACE FOR FIVE EXPANSION MODULES SHOWN WITH POWER SUPPLY AND BATTERY] – INTERNAL VIEW	9
FIGURE 9 – C1633 FIELD WIRING CONNECTIONS	11
FIGURE 10 – C1634 FIELD WIRING CONNECTIONS....	11
FIGURE 11 – C1635 FIELD WIRING CONNECTIONS....	11
FIGURE 12 – TYPICAL INTERNAL WIRING DIAGRAM FOR PRECEPT ^{EN} 8/16, 8/16 EXP AND EXP 4 OUTPUT MODULE PANELS	16
FIGURE 13 – TYPICAL INTERNAL WIRING DIAGRAM FOR PRECEPT ^{EN} 8 OR 16 WITH EXP 4 OUTPUT MODULE PANEL WITHOUT PSU.....	17
FIGURE 14– TYPICAL INTERNAL WIRING DIAGRAM FOR PRECEPT ^{EN} 8, 16 OR 32 WITH EXP 5 OUTPUT MODULE PANEL INCLUDING PSU	18
FIGURE 15– TYPICAL INTERNAL WIRING DIAGRAM FOR PRECEPT ^{EN} 32 WITH EXP 5 OUTPUT MODULE PANEL WITHOUT PSU.....	19
FIGURE 16– TYPICAL INTERNAL WIRING DIAGRAM FOR PRECEPT ^{EN} 8 OR 16 EXP WITH EXP 4 OUTPUT MODULE PANEL INCLUDING PSU	20

1 General Description.

The optional output expansion system provides a range of output modules for use within the same panel as the Precept^{en} 8 or 16 or in an additional enclosure adjacent to the Precept^{en} 8, 16 and 32 zone panels. The system comprises an interface PCB and three PCBs providing various output expansion options.

A total of 12 modules can be supported via a serial comms link from the Precept^{en} panel. Various output options are available which can be configured to operate on zonal or general fire conditions. Low power applications can be powered from the 24V DC auxiliary power provided by the fire alarm panel [subject to load limitations]. For higher power applications, PSUs and batteries can be accommodated in the adjacent O/P expansion module enclosure.

A limited number of modules can be accommodated in fire panel enclosures. Two output expansion enclosures are provided to match the 16 zone and 32 zone fire panels when higher quantities of modules are required.

2 General features:

- 8 off outputs per module.
- 3 off application types.
 - Type 1 – Indication output module.
 - Type 2 – Fire protection output module.
 - Type 3 – Sounder output module.
- Pre defined zone group allocation for types 1, 2 and 3. Allows a group of 8 sequential zones to be allocated to each board as follows. Zone groups are - Zones 1-8, 9-16, 17-24, 25-32.
- All field wiring terminals for 2.5mm conductors.
- Comms link to panel via ribbon cable.
- Power supply from fire panel via ribbon cable or from local PSU depending upon application.
- Maximum quantity of modules per panel. See Table 1.

Table 1 - Max Qty of O/P Modules supported by each panel

Panel	Max Qty of O/P Modules supported by each panel		
	Type 1	Type 2	Type 3
Precept ^{en} 8	1	1	1
Precept ^{en} 16	2	2	2
Precept ^{en} 32	4	4	4

3 Output Modules – Specific Features

3.1 C1633 – 8 way open collector [Type 1 – indication] module

- Typical application - zonal mimic type indicators.
- 8 zonal open collector outputs rated at 60mA each.
- 2 off 24V Auxiliary DC supply terminals protected by a self-resetting monitored fuse. [Max O/P 0.5Amps]
- Fuse failed signal indicated on Fire Panel.
- Header for optional local 24 and 0 volt power in.
- 2 off fail-safe inputs to monitor local power supply fault. [Mains failed and common PSU fault].

- DIL switches to allocate module address.
- DIL switch to select module to general output mode [all O/Ps operate for any zone in fire] operation or zonal operation.
- DIL switches to allocate zone group.
- LED indication for Module/Panel Comms Fault, Module Processor Fault, Module Power Supply Healthy.
- Any failure of the Module or loss of the DC supply that prevents the operation of the outputs will raise a Common Fault alarm on the panel.

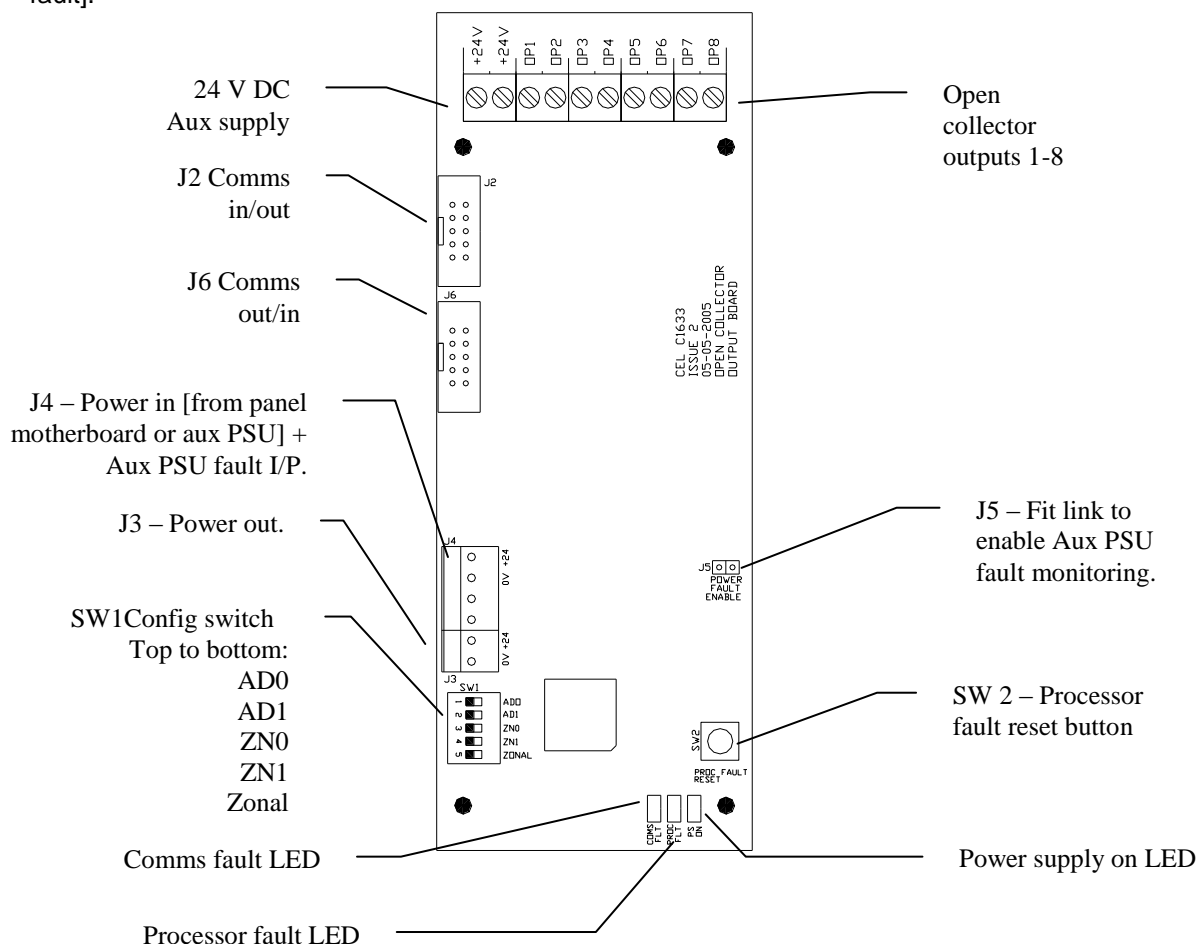

Figure 1 – C1633 PCB Layout

3.2 C1634 – 8 way volt-free relay [Type 2 Fire Protection] output module

- Typical application – non-EN54 type control of ancillary equipment.
- 8 off volt free changeover relay contacts rated at 1 Amp at 30 V DC.
- DIL switches to allocate address.
- DIL switch to select module to general output mode [all O/Ps operate for any zone in fire] operation or zonal operation.
- DIL switches to allocate zone group.

- LED indication for Module/Panel Comms Fault, Module Processor Fault, Module Power Supply Healthy.
- Any failure that prevents the operation of an output is indicated on the panel as Fire Protection Fault.
- All type 2-module outputs are disabled by the common Fire Protection disablement facility provided by the Precept^{en}.

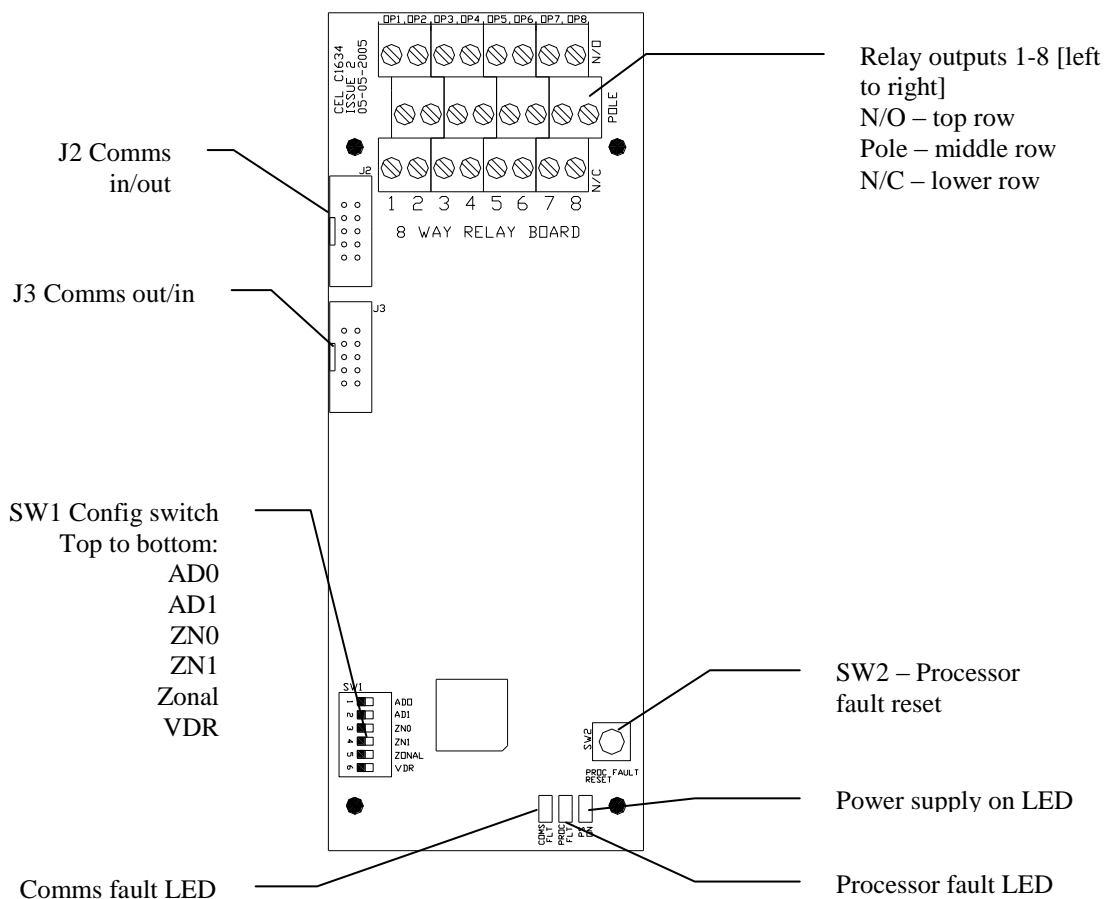

Figure 2 - C1634 PCB Layout

3.3 C1635 – 8-way monitored/powered relay [Type 2 Fire Protection or Type 3 Alarm] output module.

- 8 off fault monitored, powered outputs, all open/short circuit fault monitored. Outputs provide a 24 /0VDC output in the alarm [active] condition.
- Terminals for optional local 24 and 0 volt power in.
- 2 off fail-safe inputs to monitor local power supply fault. [Mains failed and common PSU fault].
- 8 off zonal fault LEDs to indicate a fault detected condition on each output.
- DIL switch for site configuration as type 2 [all Fire Protection Outputs] or type 3 [all sounder circuits].
- DIL switches to allocate address.

- DIL switches to allocate zone group.
- LED indication for Module/Panel Comms Fault, Module Processor Fault, Module Power Supply Healthy.
- Synchronised pulsed alarms across all sounder modules via a special command code implemented in the comms protocol.
- Any failure that prevents the operation of an output is indicated on the panel as Fire Protection Fault or Sounder Fault depending on the module type configuration.
- When configured as type 2 modules, all outputs are disabled by the Precept^{en}'s common Fire Protection disablement facility. When configured as type 3, all outputs are disabled by the common Sounder disablement facility.

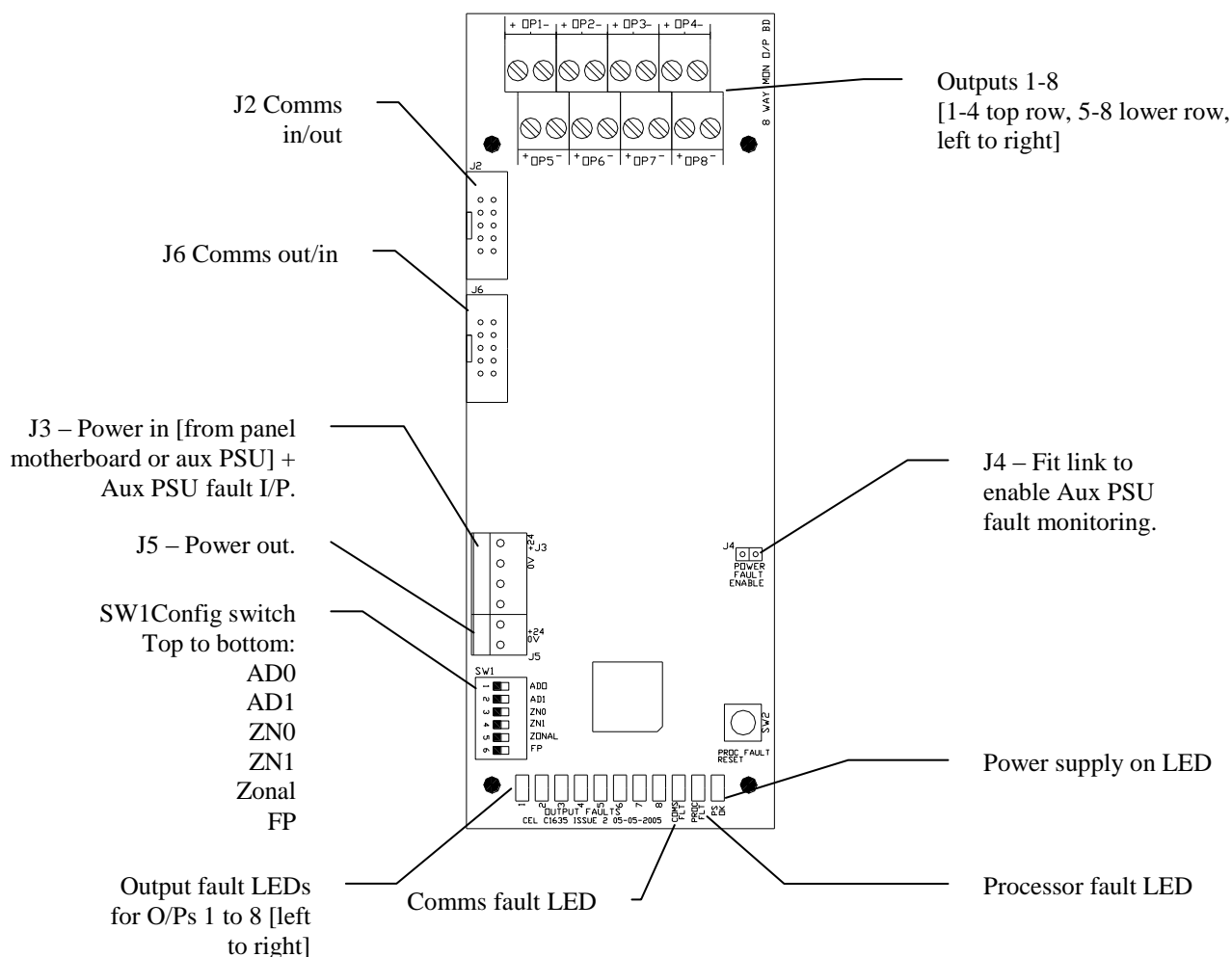

Figure 3 - C1635 PCB Layout

C1630 Output Interface

This PCB provides the RS485 communications between the panel and output modules. It includes a 7-way DIL switch used to set up the total quantity of each type of O/P module connected to the panel. The C1630 is plugged into sockets J4 and J5 located in the upper right hand quarter of the C1627 motherboard, under the fault routing relay. The 2 sockets are dissimilar which assists the correct fitting and orientation of the PCB [see Figure 5 and Figure 6].

4 Output Module Enclosures

4.1 Precept^{en} 8/16 Expansion Options

Precept^{en} 8 and 16 have space within their standard enclosures for a single I/O board as shown in Figure 5.

Precept^{en} 8 and 16 are available in an extended enclosure with space for two I/O boards as shown in Figure 6. The 8 zone panel has the standard 3 Amp PSU whereas the 16 zone panel has a C1652 5Amp PSU fitted in place of the standard 3 Amp version to cater for an additional output load.

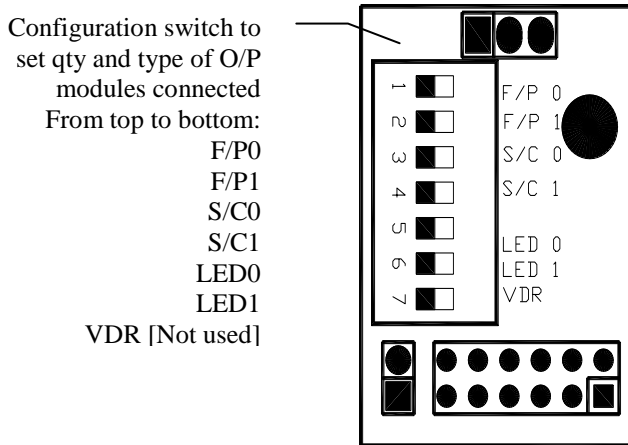

Figure 4 – C1630 PCB Layout

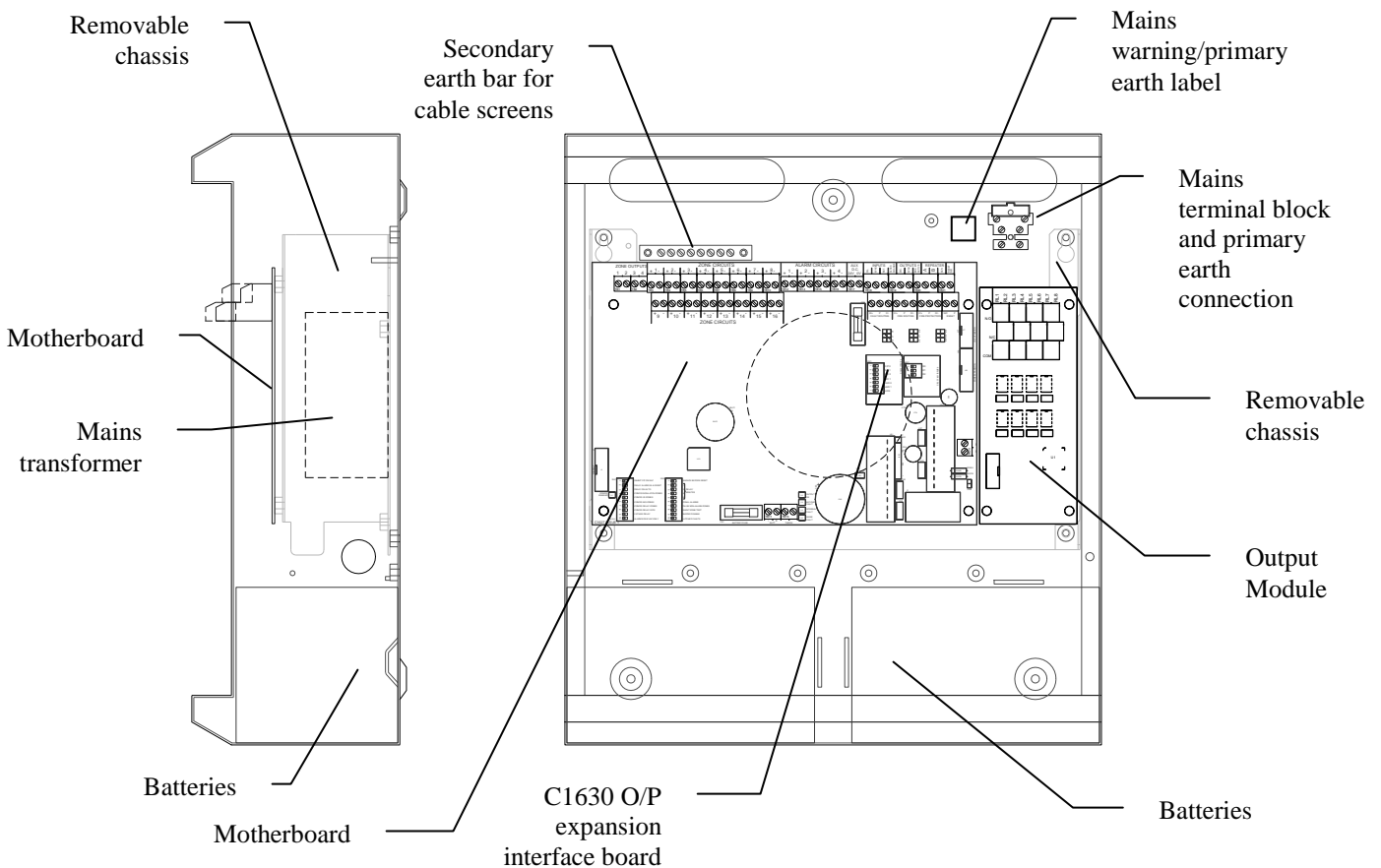

Figure 5– Precept^{en} 8/16 [with single IO board fitted internally] –internal view

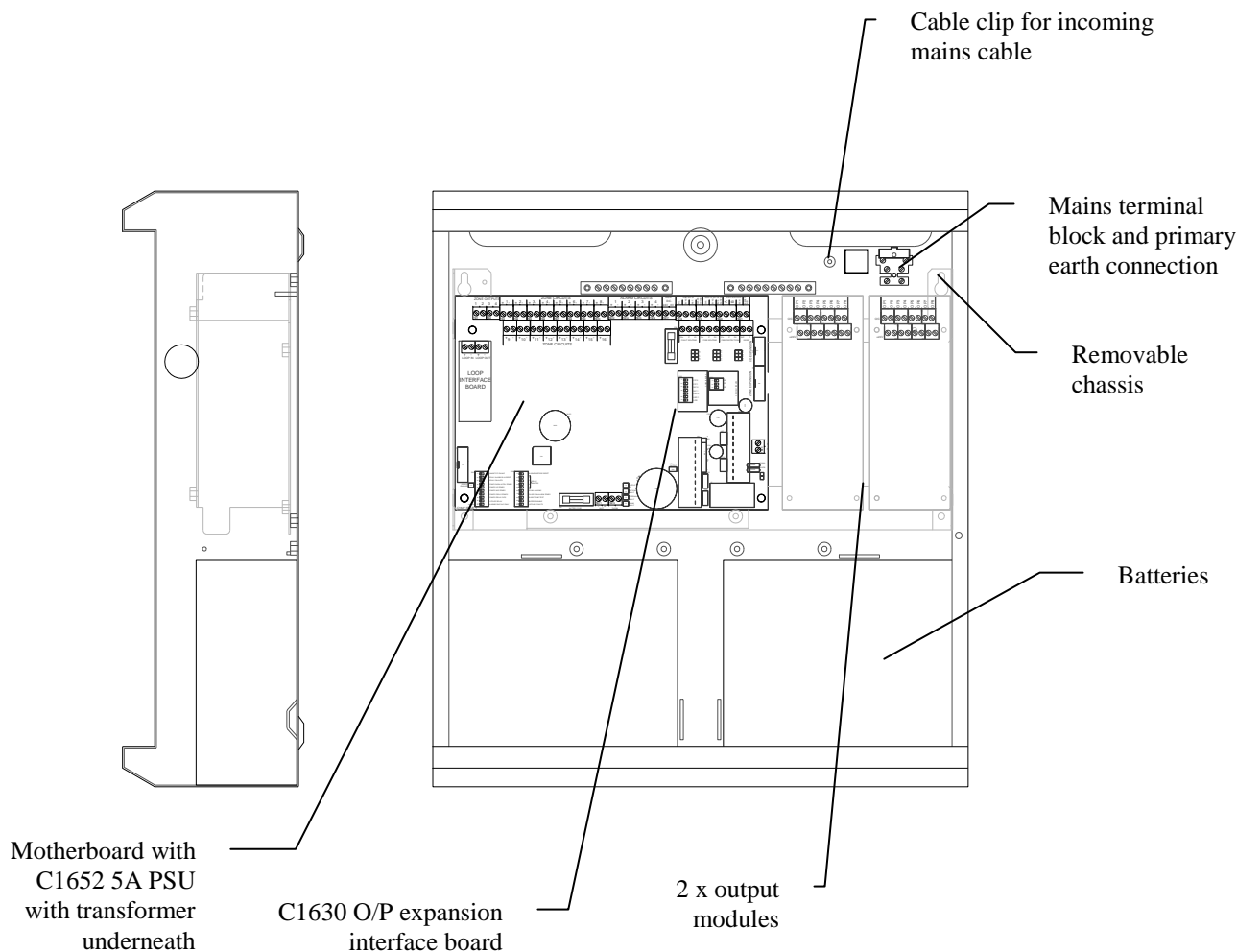

Figure 6 – Precept^{en} 16 Exp [32 zone enclosure with two IO boards] – internal view

Expansion beyond two boards is provided by the addition of a separate enclosure as described in 4.2 below.

4.2 Precept^{en} 32 Expansion Options

The 32-zone panel has no space for expansion within the standard product. All expansion is provided in a separate enclosure described in 4.3 below

4.3 Dedicated Output Expansion Enclosures

Expansion beyond the capabilities of enclosures already described is provided by two external expansion boxes, one to match the Precept^{en} 16 fire panel enclosure and the other to match the Precept^{en} 32. These enclosures are fitted with a

completely blank door hinged at the right and include space for an optional C1632 5A power supply.

The enclosures are designed to be installed to the right of the fire panel enclosure. O/P expansion wiring passes between the panel and expansion enclosures through a 25mm knockout on the right of the panel and the left of the expansion box. The boxes can be joined by a 25mm cable bush to provide enclosure integrity and mechanical alignment.

In the unlikely event of more than five modules being required on a 32-zone panel, these can be provided in further expansion boxes of five modules, joined in the same way. The second and subsequent boxes will require spacing apart to avoid door interference between the doors when opening the third and subsequent enclosures.

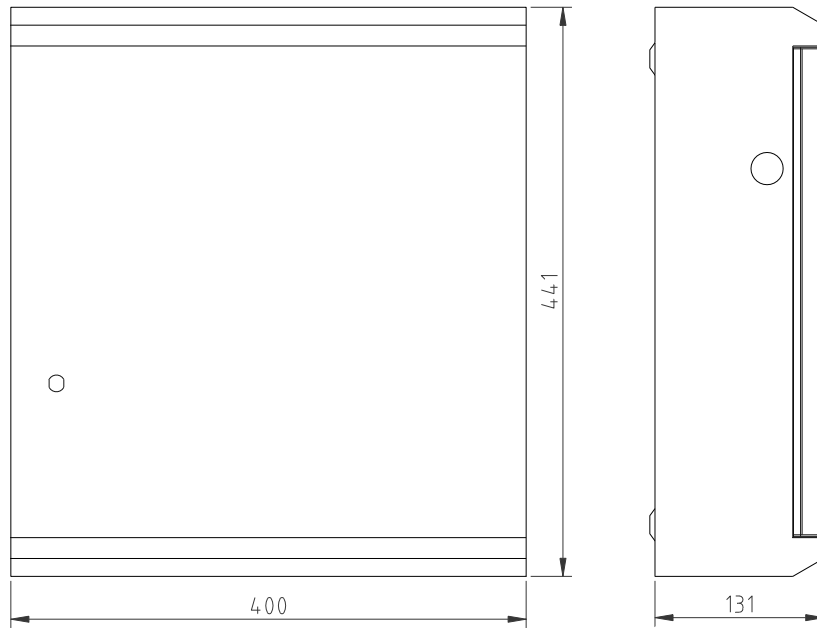

Figure 7 – Precept^{en} 5-way expansion board enclosure – external view

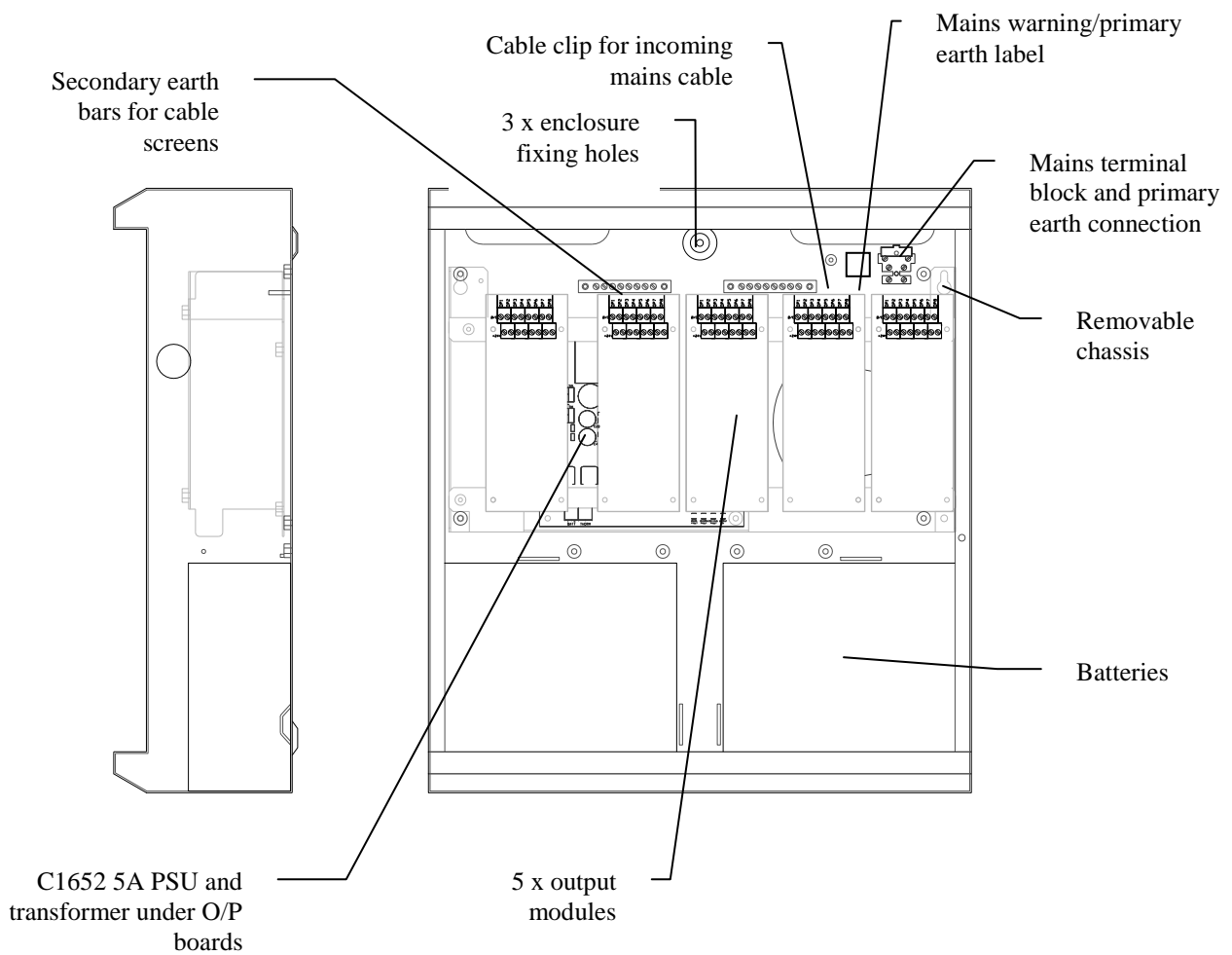

Figure 8 – Precept^{en} Exp 5 [5-way expansion board enclosure with space for five expansion modules shown with power supply and battery] – internal view

5 Ordering Information

Part Number	Description
2605102	Precept ^{en} 8 [with 3 Amp PSU] in enclosure with space for 1 x O/P modules. Note: Order 2605330 and output board separately.
2605103	Precept ^{en} 16 [with 3 Amp PSU] in enclosure with space for 1 x O/P modules. Note: Order 2605330 and output board separately.
2605105	Precept ^{en} 8 and 3A PSU in expanded enclosure with space for 2 x O/P modules. Note: Includes C1630 interface and cable. Order output boards separately.
2605106	Precept ^{en} 16 and 5A PSU in expanded enclosure with space for 2 x O/P modules. Note: Includes C1630 interface and cable. Order output boards separately.
2605326	Precept ^{en} Exp 4. Four way expansion board enclosure (includes board fixings, earth bars). Note: Order output boards [c/w wiring] separately.
2605327	Precept ^{en} Exp 4. Four way expansion board enclosure with 5A power supply (includes board fixings, earth bars and internal power lead). Note: Order output boards [c/w wiring] separately.
2605328	Precept ^{en} Exp5. Five way expansion board enclosure (includes board fixings, earth bars). Note: Order output boards [c/w wiring] separately.
2605329	Precept ^{en} Exp 5. Five way expansion board enclosure with 5A power supply (includes board fixings, earth bars and internal power lead). Note: Order output boards [c/w wiring] separately.
2605330	Precept ^{en} IO expansion installation kit (includes C1630 expansion interface and fixing screws). Note: Required to use expansion boards with parts 2605102, 2605103 and 2605104 [32 zone panel] only
2605063	C1633 8 way open collector output board, ribbon cable and power lead
2605064	C1634 8 way relay board and ribbon cable [power lead not required]
2605065	C1635 8 way alarm board, ribbon cable and power lead

6 Field Wiring Connections

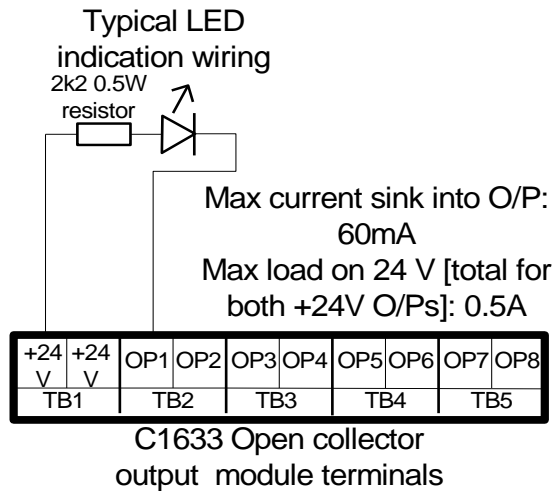

Figure 9 – C1633 Field Wiring Connections

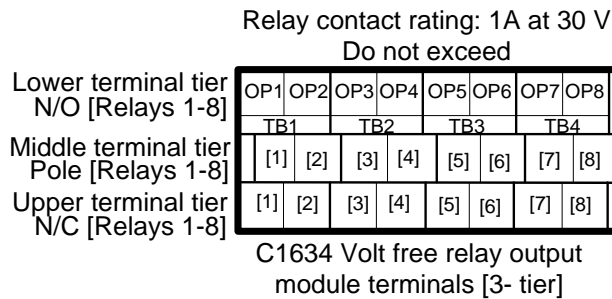

Figure 10 – C1634 Field Wiring Connections

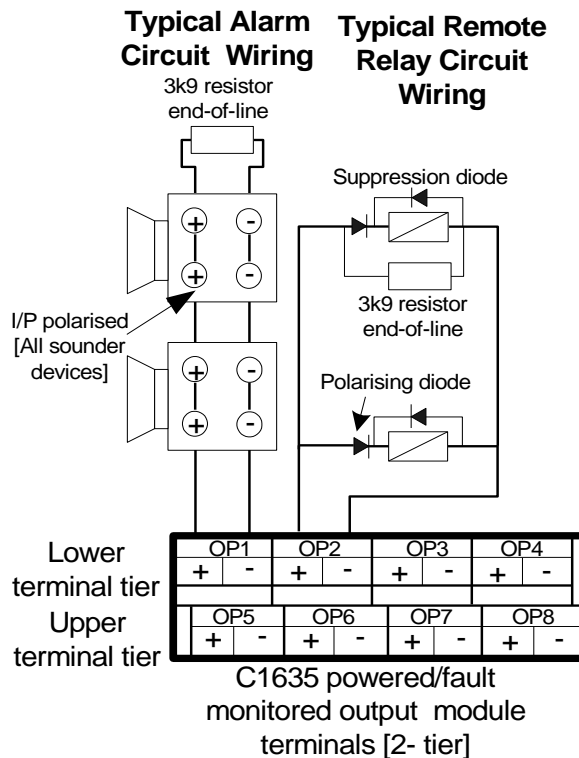

Figure 11 – C1635 Field Wiring Connections

7 Mechanical, Electrical & Environmental Specification for Expanded Panels

Table 2 – Mains Input Specification

Mains Input Specification	Expansion Panel			
	Precept ^{en} 8 with 1 x O/P module	Precept ^{en} 16 Exp	Precept ^{en} Exp 4	Precept ^{en} Exp 5
Maximum Input Power:	165W	240W	240W	240W
Protection: [Warning: Replace only with identical type & rating of BEAB or VDE approved fuse]	T3.15A H250V [3.15A anti-surge]	T3.15A H250V [3.15A anti-surge]	T3.15A H250V [3.15A anti-surge]	T3.15A H250V [3.15A anti-surge]
Voltage:	230V AC +10%/-15%			
Cable requirements:	Minimum of 1mm ² copper protected by a 5A fuse.			

Table 3 - Power Supply Unit Output Specification

Power Supply Output Specification	Expansion Panel			
	Precept ^{en} 8 with 1 x O/P module	Precept ^{en} 16 Exp	Precept ^{en} Exp 4 [2605327]	Precept ^{en} Exp 5 [2605329]
Maximum Short Term Current Output (I max b)	3A	5A	5A	5A
Maximum Continuous Current Output (I max a)	2A	2A	2A	2A
Minimum Output Current (I min)	N/A (PSU is part of the motherboard)	0A	0A	0A
Voltage Output, Mains On	26.5 - 28.6V (27.3V Nominal)			
Maximum Current Output, Mains Failed	3A	5A	5A	5A
Voltage Output, Mains Failed [* at full load]	20.0* - 28.6V	20.0* - 28.6V	20.0* - 28.6V	20.0* - 28.6V
Max Ripple including switching spikes [full load/battery disconnected] (mV p-p)	200	750	750	750
Output Voltage adjustment:	Factory Set			
Output protection:	Electronic current limiting			
Common fault output:	N/A	25mA	25mA	25mA
Mains failed fault output:	N/A	25mA	25mA	25mA

Table 4 - Battery Specification

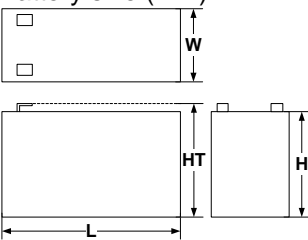
Battery Specification	Expansion Panel			
	Precept ^{en} 8 and 16 with 1 x O/P module	Precept ^{en} 8 and 16 Exp [2 O/P modules]	Precept ^{en} Exp 4 [4 O/P modules]	Precept ^{en} Exp 5 [5 O/P modules]
Battery charger output: [Temperature compensated float charger 28.6V ±0.1V@-5°C 26.5 V±0.1V@ +40 °C.	3A	5A	5A	5A
Maximum internal resistance of battery & charger circuit (Ri max)	0.6Ω	0.35Ω	0.35Ω	0.35Ω
Battery type: POWERSONIC [Warning: Replace only with identical battery]	2 off PS1270 [12V 7Ah]	2 off PS12180 [12V 18Ah]	2 off PS12120 [12V 12Ah]	2 off PS12180 [12V 18Ah]
Battery size (mm): 	L = 151 W = 65 H = 94 HT = 98	L = 181 W = 76 H = 167 HT = 167	L = 151 W = 98 H = 94 HT = 100	L = 181 W = 76 H = 167 HT = 167
Battery circuit protection: [Warning: Replace only with identical type & rating of fuse]	F5AL250V 20mm fast blow glass fuse	F6.15A L250V 20mm fast blow glass fuse	F6.15A L250V 20mm fast blow glass fuse	F6.15A L250V 20mm fast blow glass fuse
Mains failed fault battery current:	45mA + module current	50mA + module current	17mA + module current	17mA + module current
Mains failed alarm battery current:	80mA + module current	85mA + module current	17mA + module current	17mA + module current

Environmental Specification	All Panels
Operating temperature:	-5°C to 40°C
Operating humidity:	5% to 95%

8 Expansion Module – I/O Specification

Table 5 - Expansion Module Signalling O/P Specification

Expansion Module Signalling O/Ps		C1633	C1634	C1635
Qty of Outputs/module		8	8	8
Output description		Open collector	Single pole change over volt-free relays	2 wire, reverse polarity open and short circuit fault monitored, powered when activated.
Output Operating conditions	Quiescent	Off.	De-energised	Fault monitoring mode
	Alarm	On	Energised	Powered
Activated O/P		60mA 30 V max	Volt-free contacts rated 1Amp at 30VDC. Do not exceed.	0.5 A at 24 V [nom] [Subject to PSU limitations]
O/P Protection		Protection [Self resetting electronic] Fuse rating 0.5A	N/A	Protection [Self resetting electronic] Fuse rating 0.5A
Cable requirements		No special requirements.	N/A	No special requirements. 1A minimum current rating. Minimum voltage at end-of-line must be above sounding device minimum operating voltage.

Table 6 - Expansion Module 24V Auxiliary Supply O/P Specification

Expansion Module 24V Auxiliary Supply O/Ps	C1633	C1634	C1635
Qty	2	N/A	N/A
Maximum Current:	0.5A total for the 2 O/Ps	N/A	N/A
Auxiliary supply (battery operation):	20–27 VDC	N/A	N/A
Auxiliary supply (mains operation):	28.6 – 26.5 V DC	N/A	N/A
Protection: [Electronic]	0.5 A	N/A	N/A
Cable requirements	No special requirements.	N/A	N/A

Table 7 - Expansion Module Input Specification

Expansion Module Inputs	C1633	C1634	C1635
PSU and Mains Failed I/Ps [local I/P]	Non-fault monitored. 0V I/P to activate. I/P sensitivity: 0-1k Ohm	N/A	Non-fault monitored. 0V I/P to activate. I/P sensitivity: 0-1k Ohm

Table 8 - Expansion Module Power Consumption Specification

Expansion Module Power Consumption	C1633	C1634	C1635
Quiescent (including mains failed)	15mA	15mA	20mA
All outputs active (including mains failed)	25mA [Not including field load]	70mA	95mA [Not including field load]

Table 9 – Output Expansion Panels – Module Accommodation, PSU Options and Mechanical Details

Panel	Part Number	Panel Description	Number of Modules in enclosure	PSU options	Enclosure Dimensions W H D [mm]	Weight, excluding batteries	Top Entry cable Entry Knock-outs
Precept ^{en} 8	2605102	Standard Precept ^{en} 8 panel	1	230V 3A [Part of Panel]. 7 or 12Ah battery	370 325 126	7.1kg	26
Precept ^{en} 8 Exp	2605105	Expanded Precept ^{en} 8 in 32 zone enclosure	2	230V 3A [Part of Panel]. 7 or 12Ah battery	441 400 131	8kg	32
Precept ^{en} 16	2605103	Standard Precept ^{en} 16 panel	1	230V 3A [Part of Panel]. 7 or 12Ah battery	370 325 126	7.1kg	26
Precept ^{en} 16 Exp	2605106	Expanded Precept ^{en} 16 in 32 zone enclosure	2	C1652 230V 5A PSU 7,12 or 18Ah battery	441 400 131	9.3kg	32
Precept ^{en} Exp 4 [no PSU]	2605326	4-module O/P expansion enclosure with blank door. Matches Precept ^{en} 8/16 zone enclosure.	4	No PSU	370 325 126	5.1kg	26
Precept ^{en} Exp 4 [with PSU]	2605327	4-module O/P expansion enclosure with blank door. Matches Precept ^{en} 8/16 zone enclosure.	4	230V 5A 7 or 12Ah battery	370 325 126	8.4kg	26
Precept ^{en} Exp 5	2605328	5-module O/P enclosure with blank door. Matches Precept ^{en} 32 zone enclosure.	5	No PSU	441 400 131	5.9kg	32
Precept ^{en} Exp 5	2605329	5-module O/P enclosure with blank door. Matches Precept ^{en} 32 zone enclosure.	5	230V 5A with 3,7,12 or 18Ah battery	441 400 131	9.2kg	32

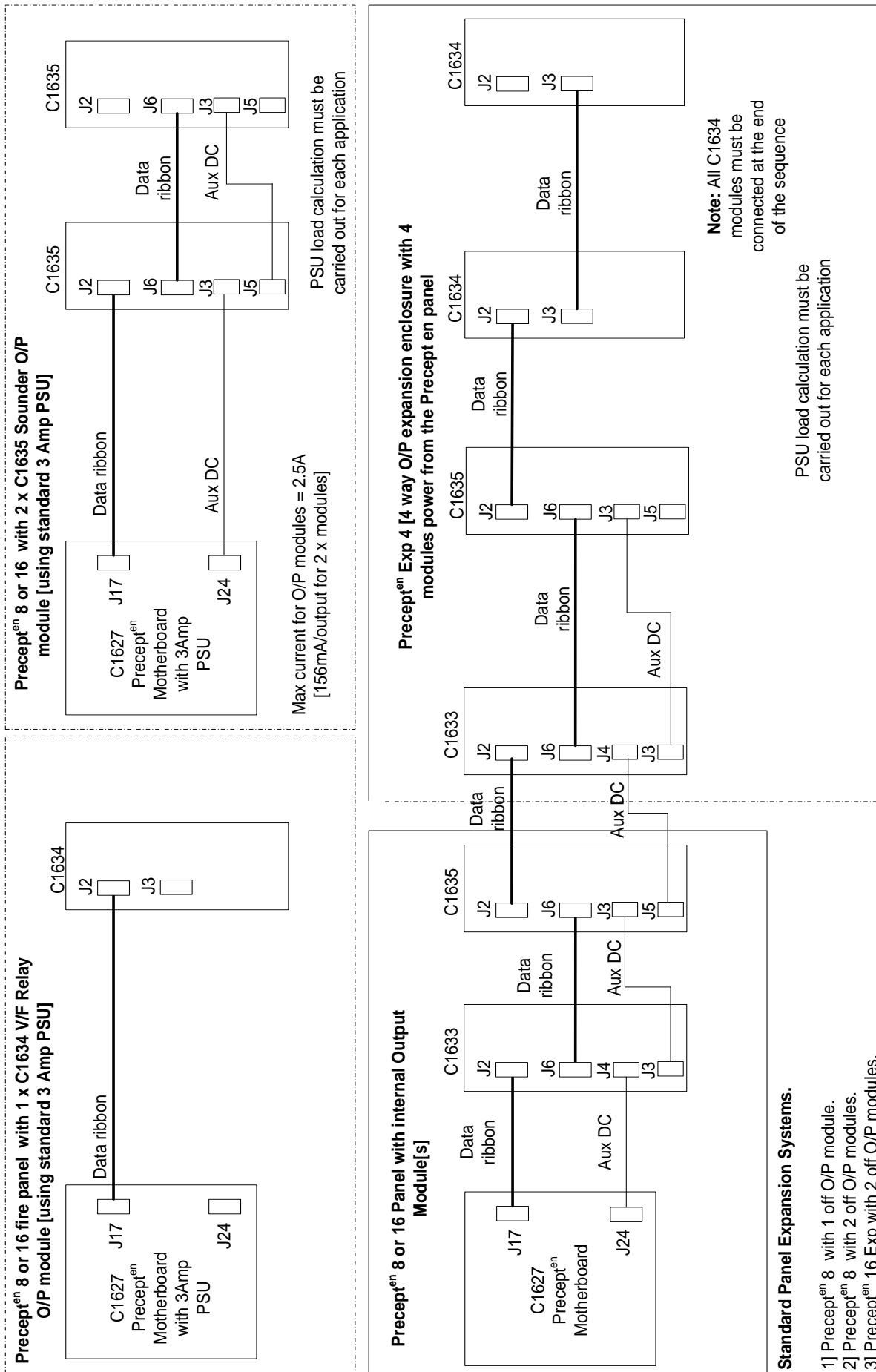

Note: To reduce the quantity of standard cable looms, any modules that are to be powered from the fire alarm panel need to be located in the left hand side of the output expansion enclosure.

Standard Panel Expansion Systems.

- 1] Precept^{en} 8 with 1 off O/P module.
- 2] Precept^{en} 8 with 2 off O/P modules.
- 3] Precept^{en} 16 Exp with 2 off O/P modules.
- 4] Precept^{en} 16 with Exp 4 [4 way O/P enclosure with max 4 O/P modules, with or without optional 5 Amp PSU and batteries].
- 5] Precept^{en} 32 with Exp 5 [5 way O/P enclosure with max 5 O/P modules, with or without optional 5 Amp PSU and batteries].

Figure 12 – Typical internal wiring diagram for Precept^{en} 8/16, 8/16 Exp and Exp 4 Output Module Panels

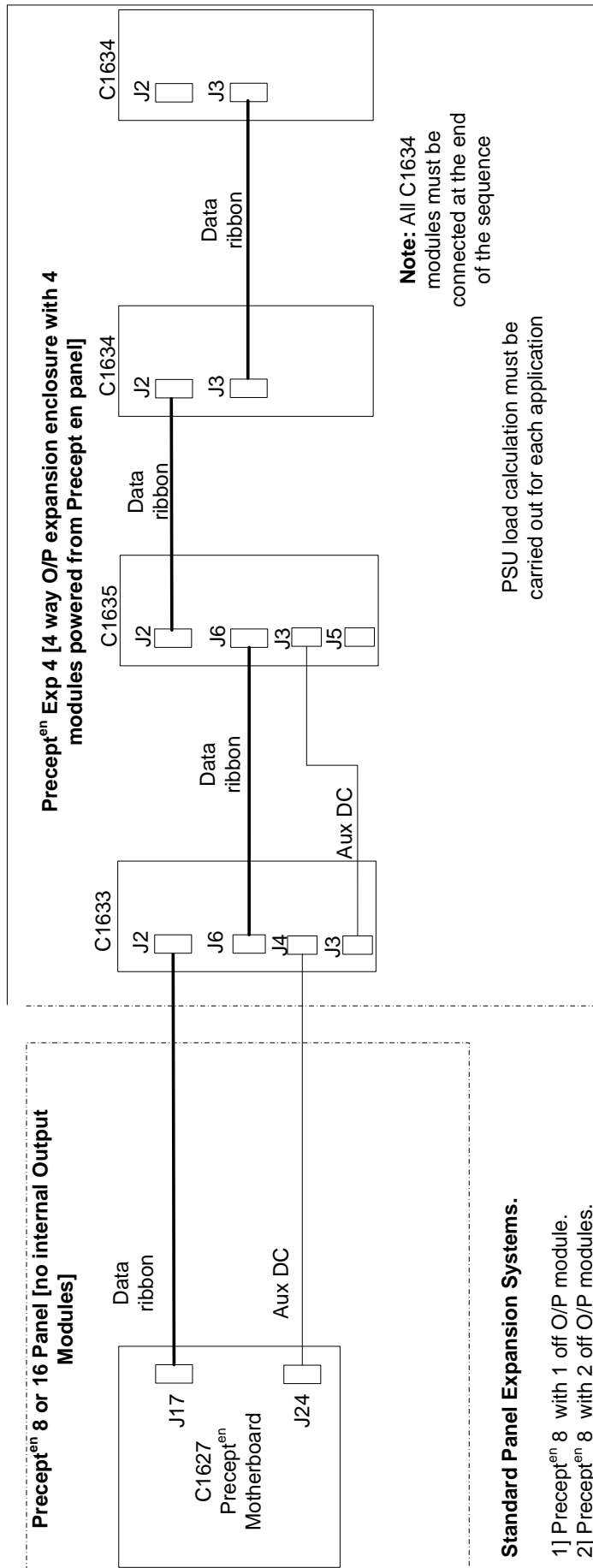

Note: To reduce the quantity of standard cable looms, any modules that are to be powered from the fire alarm panel need to be located in the left hand side of the output expansion enclosure.

Figure 13 – Typical internal wiring diagram for Precept^{en} 8 or 16 with Exp 4 Output Module Panel without PSU

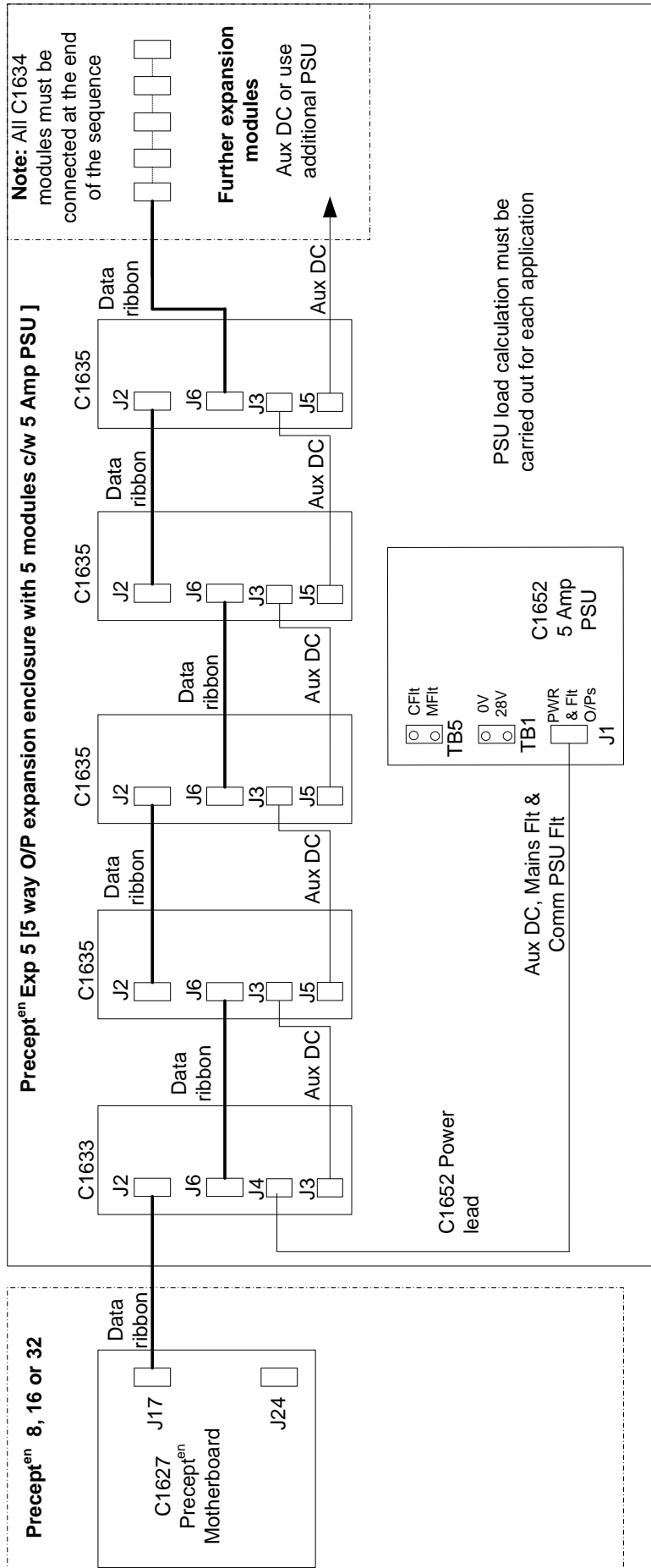

Note: To reduce the quantity of standard cable looms, any modules that are to be powered from the fire alarm panel need to be located in the left hand side of the output expansion enclosure.

Figure 14– Typical internal wiring diagram for Precept^{en} 8, 16 or 32 with Exp 5 Output Module Panel including PSU

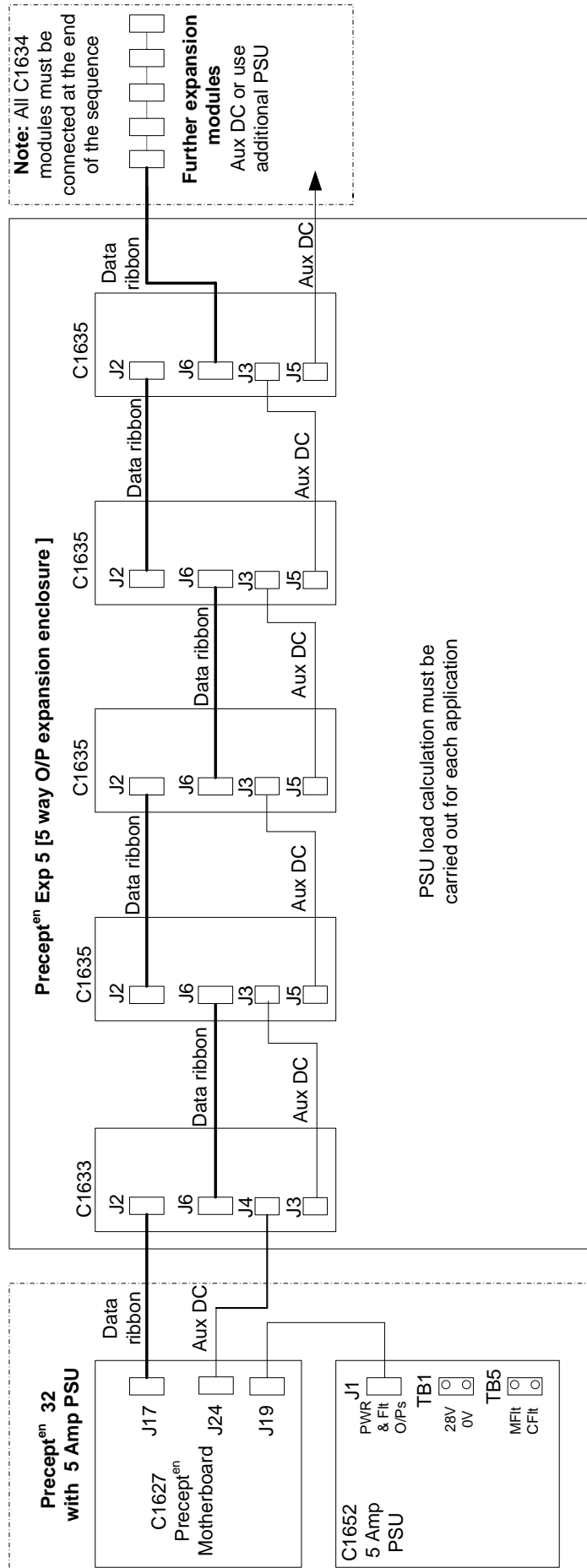

Figure 15– Typical internal wiring diagram for Precept^{en} 32 with Exp 5 Output Module Panel without PSU

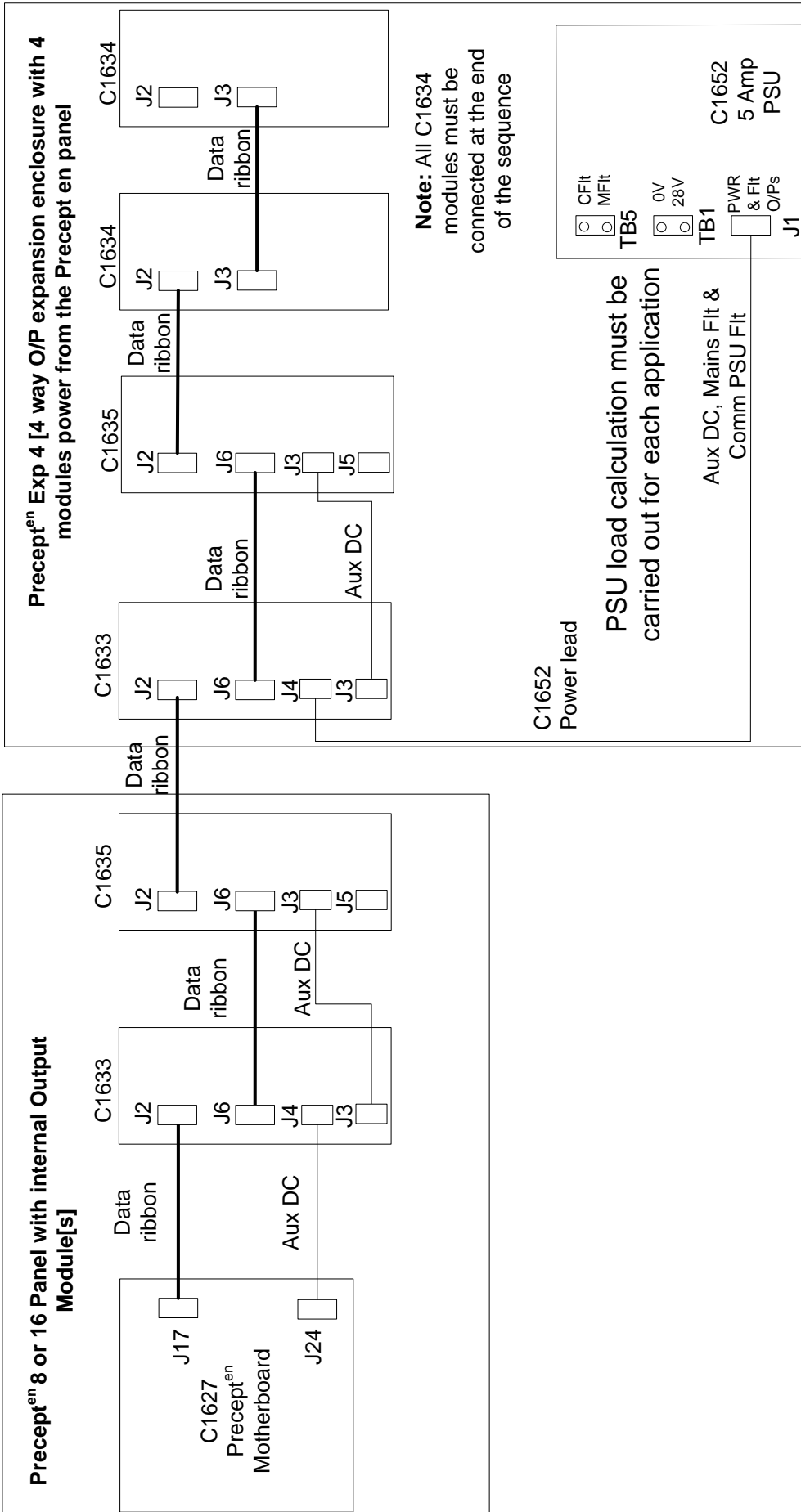

Figure 16– Typical internal wiring diagram for Precept^{en} 8 or 16 Exp with Exp 4 Output Module Panel including PSU