

*Application Guide
for the
CEL Manufactured Outstations
(A1444, A1445, A1446, A1447)*

<i>Contents</i>	<i>Page</i>
1.0 <u>Introduction</u>	2
2.0 <u>Field Device Order Codes & Descriptions</u>	3
3.0 <u>An Introduction to the CEL Outstations</u>	4
4.0 <u>Typical Schematic Illustrations</u>	5
5.0 <u>Input / Output Responses</u>	7
6.0 <u>Outstation Enclosures</u>	9
 <i><u>Appendix</u></i>	
i <u>Other Relevant Documentation</u>	9

2.0 Order Codes & Descriptions

Part No	Description
2500/236	A1444 basic outstation board (3 inputs)
2500/237	A1445 relay outstation board (3 inputs, 3 relays)
2500/238	A1446 sounder outstation board (3 inputs, 1 sounder circuit, 1 relay)
2500/240	A1447 add-on zone monitor board for above outstation boards
2501/149	Enclosure to fit 1 outstation board; Size - 150h x 225w x 75d
2500/197	Enclosure c/w 1A psu & space for one outstation board & 3.2AH battery set Size - 300h x 350w x 75d
2500/221	Enclosure c/w 3A psu & space for four outstation boards & 6.2AH battery set Size - 380h x 600w x 210d
2500/223	Enclosure c/w 5A psu & space for five outstation boards & 6.2AH battery set Size - 600h x 600w x 210d

3.0 An Introduction to the CEL Outstations

The A1444, A1445, A1446 and A1447 outstations are a series of modules designed to allow loop input and output functions when used with the Duplex, Discover, Nexus and R3 analogue addressable panels. Each outstation is configured to the required address number and its input/output response by setting its DIL switch. They are supplied as either boxed or boxed with a power supply and battery space.

The maximum number of output devices that may be fitted to each loop is determined within the panel's Cause/Effect programming and the Battery and Loop Calculation Spreadsheet. {Please refer to the Relevant Application Guide and the Programming Guide}

3.1 Outstation Facilities

- 3.1.1 A1444** Allows remote monitoring of 3 voltage free contacts, either normally open or normally closed. Inputs are prioritised. Input 1 will override input 2, input 2 will override input 3. Powered from the detection loop.
- 3.1.2 A1445** As A1444, except with the addition of 3 independently programmable output changeover relays (contacts rated 8A @ 30V DC). External power supply required (500mA minimum required).
- 3.1.3 A1446** As A1444, except with the addition of one 2 stage alarm circuit and one changeover programmable relay (750mA alarm circuit, 1A @ 30V DC relay contact). External power supply required (1 Amp minimum).
- 3.1.4 A1447** Will fit to A1444, A1445, A1446 to convert 1 or 2 of the inputs to monitored detection zones. External power supply required (100mA minimum).

WARNING: *Do not exceed the rated voltage or current of the output relays.*

4.0 Typical Schematic Illustrations

4.1 Typical Schematic Illustration for A1444 and A1445 Outstations

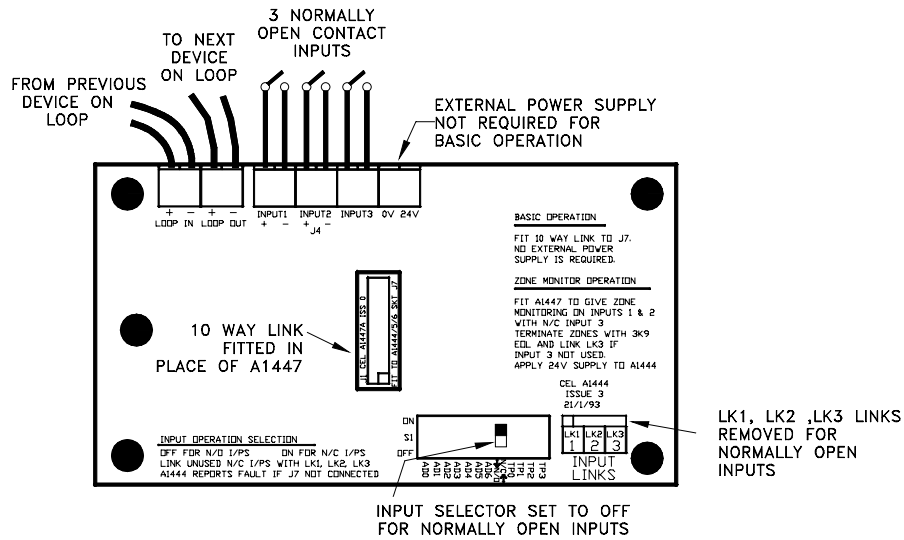

A1444 MONITORING 3 NORMALLY OPEN INPUT SWITCHES

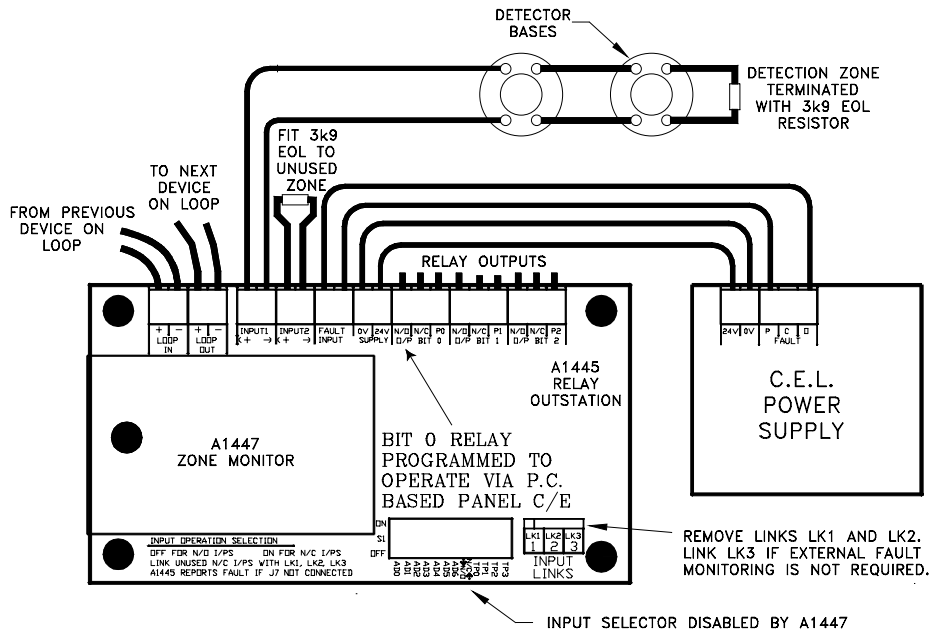

A1445 RELAY OUTSTATION FITTED WITH A1447 ZONE MONITOR

4.2 Typical Schematic Illustration for A1446 Outstation

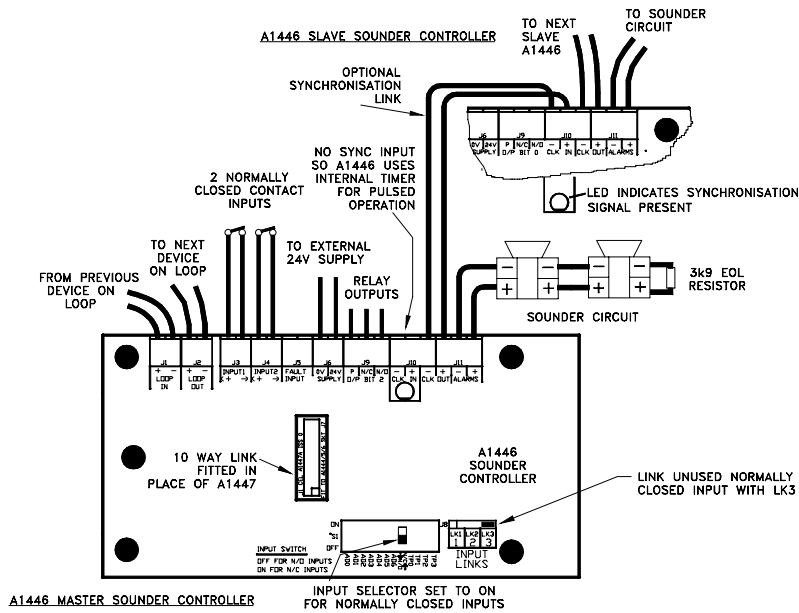

TERMINATION EXAMPLE 3:

A1446 SOUNDER CONTROLLER WITH SYNCHRONISED PULSED ALARM OPERATION MONITORING TWO NORMALLY CLOSED SWITCHES

5.0 Input and Output Responses

The following chart lists the input/output responses by type code setting the unit's DIL switch.

The columns are as follows:

Part number	The most suitable product for the type code setting listed.
Type	A description of its type function.
Code	The type code number.
Input (IP 1,2,3)	The three outstation inputs. The columns describe the text display response at the control panel. Mode 1, 2 & 3 indicate on the panel display and sound its internal buzzer only. Alert/Valve closed will put the panel into its alert mode with full display operation but no alarm circuit operation. Fire will cause the panel to give a normal fire response. Fault will cause the panel to give a fault display and operate the common fault relay. Refer to Programming Guide/Disk for cause/effect programming options..
Programmable Output Channel A, B, C	Independent programmable outputs. Prog. indicates that the function is programmable by the panel's cause/effect. The terminology "Channel A,B,C" appears on the PC-based panel cause & effect programme. All other output responses are pre-set and cannot be changed.

NOTE: *Channels A,B,C correspond to the Apollo output bits 0,1,2, respectively.*

5.1 Input and Output Response Chart

Part no.	Description	Type Code	I/P 1	I/P 2	I/P 3	Programmable Output Channel		
						BIT 0	BIT 1	Bit 2
A1446	SOUNDER CONTROL	1	mode 1	mode 2	remote fault	cont. prog.	pulsed prog.	prog. v/f relay
A1445	I/O UNIT (When used with the Duplex and Nexus panels)	2	fire	input	remote fault	prog.	prog.	prog.
A1445	I/O UNIT (When used with the Discovery and R3 panels)	2	mode 1	mode 2	mode 3	prog.	prog.	prog.
A1445	ION. SMOKE	3	fire	alert	data flt	rem. lamp	dev. test	dev. led
A1444/7	ZONE MON. (When used with Duplex and Nexus)	4	fire	alert	remote flt	on reset	prog.	prog.
A1444/7	ZONE MON. (When used with the Discovery and R3)	4	fire	valve closed	rem. flt	on reset	prog.	prog.
A1445	OPTICAL SMOKE	5	fire	alert	data flt	rem. lamp	dev. test	dev. led
A1445	HEAT DETECTOR	6	fire	alert	data flt	rem. lamp	dev. test	dev. led
A1445	PRIORITY DEV.	7	fire	dev. flt	data flt	rem. lamp	dev. test	dev. led
DO NOT USE	----	8	----	----	----	----	----	----
DO NOT USE	----	9	----	----	----	----	----	----
DO NOT USE	----	10	----	----	----	----	----	----
DO NOT USE	----	11	----	----	----	----	----	----
DO NOT USE	----	12	----	----	----	----	----	----
DO NOT USE	----	13	----	----	----	----	----	----
DO NOT USE	----	14	----	----	----	----	----	----
DO NOT USE	----	15	----	----	----	----	----	----

5.3 Notes

- 5.3.1** The A1444 may be configured for any type code setting and will give the appropriate input response. No outputs are available.
- 5.3.2** The A1444 fitted with the A1447 may be used for remote monitoring of smoke detectors, call points or switches.
- 5.3.3** Type 4 automatically generates a reset bit on channel A for 10 seconds.
- 5.3.4** When used with the A1446, it is not possible to provide a latching/reset facility through the A1447. Therefore non-latching monitoring only is possible.

6.0 Outstation Enclosures

The outstations are supplied in steel cabinets as listed in section 2.0.

Appendix

i Other Relevant Documentation

Application Guide for Duplex 1-2 Loop Panels
Application Guide for Discovery 1-4 Loop Panels
Application Guides for Nexus 1-8 Loop Panels
Installation and Commissioning Manual for A1444 Basic Outstation, A1445 Relay
Outstation, A1446 Sounder Controller Outstation and A1447 Zone Monitor Unit
Battery and Loop Calculation Spreadsheet