

Installation and Commissioning Manual

for

A1444 Basic Outstation, A1445 Relay Outstation,

A1446 Sounder Controller Outstation and

A1447 Zone Monitor Unit

1.0	Introduction	2
2.0	Input Operation	2
3.0	Type Codes	3
4.0	Addressing	3
5.0	Zone Monitor Operation	3
5.1	Use of the A1444/5/6 with the A1447 as a Zone Monitor Outstation	3
5.2	Connection and Operation of Zone Monitoring	4
5.3	Connection and Operation of Fault Monitoring	4
6.0	A1445 Relay Outstation Operation	5
7.0	A1446 Sounder Controller Outstation Operation	5
7.1	Connection to the Auxiliary Relay	5
7.2	Connection to Sounder Circuit	5
7.3	Synchronisation Of Multiple Sounder Controllers	5
8.0	Installation of the A1444, A1445, A1446 and A1447 Outstations	6
8.1	Connection of A1445 Relay Outstation Outputs	6
8.2	Connection of A1446 Sounder Outstation Outputs	6
9.0	Commissioning	7
9.1	Commissioning The A1444 to Monitor Voltage free Contacts	7
9.2	Commissioning A1445 Relay Outstation (to Monitor Voltage-free Contacts)	7
9.3	Commissioning A1446 Sounder Outstation (to Monitor Voltage-free Contacts)	8
9.4	Commissioning the A1444 and A1445 Outstations (for Zone Monitoring)	9
9.5	Connection of Outstations to the Loop	9
9.6	Addressing	10
9.6.1	Table Showing Address Switch Settings for CEL Outstations	10
Appendices		11
i	Outstation Specifications	11
ii	Termination Drawings	12
iii	Other Relevant Documentation	14

1.0 Introduction

The A1444 Basic Outstation, A1445 Relay Outstation and A1446 Sounder Controller Outstation are designed to allow remote monitoring of 3 voltage free contacts via the loop and communicate their status to the panel using analogue values. The A1444, A1445 and A1446 have identical input operation, addressing and type set-up, so operation of these features will be discussed in a section common to all three outstations. For this purpose the outstations will be collectively referred to as A1444/5/6.

The A1444 is a stand-alone unit which derives its power from the loop and hence needs no external power supply except when operating as a zone monitor input unit with the A1447. The A1445 has 3 single pole change over relay outputs and requires a 24V DC supply. The A1446 has a single change over relay and fully monitored sounder output circuit which can operate in pulsed or continuous mode. It also requires a 24V DC supply.

The A1444/5 can also be used as a zone monitor outstation with the addition of the A1447 Zone Monitor Board. This plugs onto the A1444/5 and provides monitoring on Inputs 1 and 2 for fire, fault and quiescent conditions, with Input 3 operating as an auxiliary fault input. The A1446 does not support zonal fire detection in conjunction with the A1447 Zone Monitor although the A1447 can be used to provide remote switch monitoring with fault detection. The A1444/5 can also be used in this mode if the inputs being monitored are remote from the outstation.

The A1447 Zone Monitor Unit derives its power from the external power supply terminals on the A1444/5/6 and optically isolates this power supply and any field wiring from the loop.

2.0 Input Operation

The 3 inputs are labelled 'INPUT 1', 'INPUT 2' and 'INPUT 3' on the A1444 and 'INPUT 1', 'INPUT 2' and 'FAULT INPUT' on the A1445/6. The outstation scans these inputs for the operation of a voltage free contact. These can be normally open or normally closed contact switches but all inputs must be of the same type. The required input mode is set using the N/O N/C DIP switch found between the address and type code switches at the lower right of the board.

By switching the input selector switch ON the inputs are monitored for normally closed inputs. By switching it OFF the inputs are monitored for normally open contacts. The A1444/5/6 responds with an analogue value of 16 if no inputs are active. If any inputs are active (not in their quiescent state) then the analogue value returned is dependent on which input is activated. The inputs are prioritised so that operation of Input 1 (analogue 64) overrides Input 2 (analogue 48) which overrides Input 3 or Fault Input (analogue 4).

The 24V external power supply terminals are not used for basic operation of the A1444 and are only connected to a local power supply when used with the A1447 Zone Monitor. If this card is not present then the power supply terminals should be left unconnected.

The A1445/6 require a 24VDC supply for normal operation. The A1444/5/6 do not require that all their inputs are utilised. If only 1 or 2 inputs are used then choice of the inputs used is dependent upon the analogue value required.

It is important for correct operation that the unused inputs are correctly configured so that the A1444/5/6 can see them as being inactive. Thus if the input selector is switched on for normally closed input operation then any unused inputs should be shorted out so that the outstation recognises them as inactive. To achieve this, shorting links LK1, LK2 and LK3 are provided on

the lower right of the board and link Inputs 1, 2 and Input 3 or Fault Input respectively. If the outstation is monitoring normally open inputs the links LK1, LK2 and LK3 should be removed.

For correct operation of the A1444/5/6 it is essential that a 2x10 way link is fitted to socket J7 in the centre of the PCB. This provides connection between the input terminals and input circuitry. If it is not present and the A1447 Zone Monitor is not fitted then the A1444/5/6 will not respond to its inputs and returns a fault condition (analogue 4).

3.0 Type Codes

The control panel responds to the analogue value returned by the outstation according to the type of device the outstation represents. This is set using the type code switches on the outstation, labelled TP0 to TP3 of S1. A summary of type codes & respective switch settings is given below. Input message responses are dependent upon panel type and may vary. Refer to the manuals for the panel for further detail.

Type	TP0	TP1	TP2	TP3	Device Type	Input 1	Input 2	Input 3
0	ON	ON	ON	ON	Spare	N/A	N/A	N/A
1	OFF	ON	ON	ON	Sounder controller	MODE 1	MODE 2	MODE 3
2	ON	OFF	ON	ON	I/O Unit 0	MODE 1	MODE 2	MODE 3
3	OFF	OFF	ON	ON	Ion Smoke	FIRE	ALERT	DATA FAULT
4	ON	ON	OFF	ON	Zone Monitor	FIRE	VALVE CLOSED	REMOTE FAULT
5	OFF	ON	OFF	ON	Optical Smoke	FIRE	ALERT	DATA FAULT
6	ON	OFF	OFF	ON	Heat Detector	FIRE	ALERT	DATA FAULT
7	OFF	OFF	OFF	ON	Priority Device	FIRE	DEVICE FAULT	DATA FAULT
8	ON	ON	ON	OFF	Do Not Use	N/A	N/A	N/A
9	OFF	ON	ON	OFF	Do Not Use	N/A	N/A	N/A
10	ON	OFF	ON	OFF	Do Not Use	N/A	N/A	N/A
11	OFF	OFF	ON	OFF	Do Not Use	N/A	N/A	N/A
12	ON	ON	OFF	OFF	Do Not Use	N/A	N/A	N/A
13	OFF	ON	OFF	OFF	Do Not Use	N/A	N/A	N/A
14	ON	OFF	OFF	OFF	Do Not Use	N/A	N/A	N/A
15	OFF	OFF	OFF	OFF	Do Not Use	N/A	N/A	N/A

4.0 Addressing

The address of the A1444/5/6 on the loop is set using the address switches AD0 to AD6, the first 7 switches of S1 on the PCB. Outstations can take any address in the range 1 to 126 although it is important to check any limitations of the control panel if outputs need to be programmed. A table of addresses and instructions is found on page 11.

5.0 Zone Monitor Operation

5.1 Use of the A1444/5/6 with the A1447 as a Zone Monitor Outstation

The A1444/5 can be used as a zone monitor outstation in conjunction with the A1447 Zone Monitor Unit. The A1447 also provides a remote switch monitoring facility for A1444/5/6. The A1447 plugs into socket J7 of the A1444/5/6 in place of the 2x10 way link and modifies input operation in the following way:

Inputs 1 & 2 are monitored for quiescent, fire and fault conditions. Input 3 becomes a normally closed contact fault input and should be linked using LK3 if no auxiliary input is connected.

The A1447 optically isolates the loop from any field wiring and the local power supply.

5.2 Connection and Operation of Zone Monitoring

Input 1 and Input 2 are now modified to become separate zones supporting up to 20 detectors or any number of break glass units. The zones are each monitored for open and short circuit faults, quiescent and fire conditions. The polarity of each zone is shown on the parent outstation beneath the corresponding input terminals. The 2 zones must be terminated with a 3k9 end of line resistor fitted in the last device. Any break glass units must be fitted in series with a 680 ohm resistor. If either zone is unused then the 3k9 resistor must be fitted to the corresponding zone terminals.

All outstations can use the A1447 Zone Monitor to monitor remote normally closed switches with the added security of cable fault monitoring. In this case a 680 ohm resistor must be fitted in series with the switch in addition to the 3k9 end of line resistor.

As the A1446 Sounder Controller Outstation does not support the zone reset facility of the A1447 Zone Monitor, the A1446 can only be used to monitor normally open switches in conjunction with the A1447.

5.3 Connection and Operation of Fault Monitoring

Input 3 becomes an auxiliary fault input and responds to a normally closed contact. It can be used to monitor a local power supply for mains or battery fault by connection to the contacts of the fault relay which are open circuit under a fault condition.

When the A1447 Zone Monitor is fitted it is essential that links LK1 and LK2 are removed. LK3 should be linked if no external fault contact is to be monitored by Input 3.

When used with the A1447 zone monitor outstation the panel will see active inputs for the following conditions:

Input 1 active	Fire condition on zone 1
Input 2 active	Fire condition on zone 2
Input 3 active	Zone fault or power failure

The response of the panel will depend upon the type code settings detailed earlier.

The A1444 and A1445 have the ability to reset or isolate both zones simultaneously. This is achieved by setting output bit 0 of the outstation high and then low. This causes the zone to be held isolated for 10 seconds. If bit 0 remains high for longer than 10 seconds the zones will be held isolated and will only be reactivated when the output bit is reset to 0.

In both cases the A1444/5 will not report a fault condition while the zone reset bit is held high. It should be noted that the 'Bit 0' relay of the A1445 will also operate while output bit 0 is held high. Activation of output bit 0 on an A1446 Sounder Outstation will have no effect on the operation of an A1447 Zone monitor fitted to it.

6.0 A1445 Relay Outstation Operation

The A1445 Relay Outstation has 3 sets of single pole change over contacts which are operated by outstation output bits 0, 1 and 2. Each set of contacts is labelled with the output bit which controls its operation, P (pole), N/C (normally closed contact) and N/O (normally open contact).

The A1445 requires a local power supply which is optically isolated from the loop by the outstation. Failure of this supply will cause the A1445 to return a fault (analogue 4). The auxiliary fault input can also be used to monitor the supply for a mains or battery fault by using the power supply fault output. The fault contacts used should be consistent with the contacts connected to Inputs 1 and 2 so that a fault condition gives an active input.

7.0 A1446 Sounder Controller Outstation Operation

The A1446 Sounder Outstation has an auxiliary single pole changeover relay and sounder circuit which is monitored for open and short circuit faults. It requires an external 24V supply. Operation is as follows:

Output Bit	Outstation Response
BIT 0	Continuous sounder operation
BIT 1	Pulsed sounder operation
BIT 2	Auxiliary relay active

NOTE: *Continuous sounder operation overrides pulsed sounder operation.*

7.1 Connection to the Auxiliary Relay

The terminals for the relay are labelled as 'BIT 2 O/P': 'P' (pole), 'N/O' (normally open) and 'N/C' (normally closed).

7.2 Connection to Sounder Circuit

The sounder circuit output is labelled 'ALARMS' and the polarity is indicated for sounders in an activate condition. Devices connected to the circuit must be reverse polarity protected to allow for circuit monitoring by the A1446. The circuit must be terminated with a 3k9 end of line resistor.

7.3 Synchronisation Of Multiple Sounder Controllers

The A1446 has the facility to synchronise activation of pulsed sounder operation. To achieve this one A1446 is selected as a master controller and any other slave controllers connected to it pulse in time with the signal generated by the master controller.

The synchronisation output on the master is labelled 'CLK OUT' and should be connected to the synchronisation input of the first A1446 slave unit. The input is labelled 'CLK IN' and connection must be 'CLK OUT +' to 'CLK IN +' and 'CLK OUT -' to 'CLK IN -'. Any further controllers are wired to the slave 'CLK OUT' terminals in the same way. At the 'CLK IN' terminals an LED indicates correct operation of the input signal. A failure of the 'CLK IN' signal causes any slave sounder to revert to its internal oscillator which will then control its own pulsed operation along with that of any further slaves wired to it.

The synchronisation signal operates independently of any sounder output and only affects operation of those controllers which are set for pulsed operation by the control panel.

8.0 Installation of the A1444, A1445, A1446 and A1447 Outstations

1. Remove the outstation from the enclosure supplied if appropriate.
2. Mount the enclosure in a suitable location and gland all field wiring in place.
3. Set the address and type code switches as described on pages 2 and 3.
4. When not using the A1447 zone monitor:
 - i) Connect voltage free contacts to the appropriate input terminals and ensure the 2x10 way connector is fitted to connector J7 of the outstation.
 - ii) Set the input selector switch which is found as switch 8 of S1 on the outstation to either normally open (N/O) or normally closed (N/C) operation as required.
 - iii) When the outstation is configured for normally open inputs remove LK1, LK2 and LK3.
 - iv) When configured for normally closed inputs fit a link to short out any unused inputs. LK1, LK2, LK3 are provided for this and correspond to Input 1, Input 2 and Input 3 / Fault Input respectively.
5. When using the outstation with the A1447 zone monitor:
 - i) Fit the A1447 to J7 on the outstation in place of the 2 x 10 way link.
 - ii) Connect the zone field wiring to Input 1 and Input 2 of the parent outstation observing correct polarity. This is indicated on the outstation.
 - iii) Ensure that both zones are terminated with a 3k9 resistor fitted at the last device, and if either zone is not used that a 3k9 resistor is fitted to the unused terminals.
 - iv) Any break glass units installed on the zones must be fitted with a 680 ohm resistor in series with the switch. Any switches which are monitored by a zone not used for fire detection must also be fitted with a 680 ohm resistor in series with the switch.
6. Connect a 24V power supply to the supply terminals if required. This may be either from the panel or from a local power supply. In the latter case it is essential to connect the power supply fault relay to Input 3 or the Fault Input. Connection must be consistent with the other inputs so that the input is active in a fault condition.
7. The 'LOOP IN' and 'LOOP OUT' terminals should not be connected at this stage.

8.1 Connection of A1445 Relay Outstation Outputs

Connect each relay output to the required field wiring leaving any unused outputs unconnected. The terminals are identified by the outstation output bit which operates the output. (i.e. BIT 0, BIT 1, BIT 2). The contacts are labelled 'P' (pole), 'N/O' (normally open contact), 'N/C' (normally closed contact).

8.2 Connection of A1446 Sounder Outstation Outputs

1. Connect any field wiring to the 'BIT 2' auxiliary relay terminals. These are labelled 'P' (pole), 'N/O' (normally open contact), 'N/C' (normally closed contact).
2. Connect the sounder circuit to the output labelled 'ALARMS' The polarity is shown for the sounder circuit activated. The circuit is reverse polarity monitored for fault conditions so all devices must be reverse polarity protected. The circuit must be terminated with a 3k9 end of line resistor fitted after the last sounder.

3. If the sounder outstation is not required to be synchronised with any others then both the 'CLK IN' and 'CLK OUT' terminals should be left unconnected.
4. If the sounder outstation is to be synchronised with other controllers the terminals labelled 'CLK IN' & 'CLK OUT' must be connected to the other controllers as follows:
 - i) If the sounder controller is the first one in the chain of synchronised controllers then the 'CLK IN' terminals should be left unconnected. If the outstation is acting as a slave controller then the 'CLK IN' terminals must be connected to the 'CLK OUT' terminals of the previous controller. Connection is 'CLK OUT +' to 'CLK IN +' and 'CLK OUT -' to 'CLK IN -'.
 - ii) The 'CLK OUT' terminals should be connected to the 'CLK IN' terminals of the next sounder controller as in (i). If the outstation is the last sounder in the synchronisation chain then the 'CLK OUT' terminals should be left unconnected.

9.0 Commissioning

9.1 Commissioning The A1444 to Monitor Voltage free Contacts

1. Connect a Hand Held Test Tool to the 'LOOP IN +' and 'LOOP OUT -' terminals. Probe sockets are provided in the terminals to simplify this.
2. Switch on the Test Tool and select option 4 – 'IDENTIFY DETECTOR' from the menu. Observe that the Test Tool responds with the correct address and type required for the outstation.
3. Ensure that all inputs are in their quiescent state and that the outstation is responding to the test tool with an analogue value of 16.
4. Operate the switch connected to Input 3 and observe that the Test Tool responds with an analogue value of 4. Return the switch to its quiescent state and observe that the Test Tool shows an analogue value of 16.
5. Operate the switch connected to Input 2 and observe that the Test Tool responds with an analogue value of 48. Return the switch to its quiescent state and observe that the Test Tool shows an analogue value of 16.
6. Operate the switch connected to Input 1 and observe that the test tool responds with an analogue value of 64. Return the switch to its quiescent state and observe that the Test Tool shows an analogue value of 16.
7. The A1444 is now tested and can be connected to the loop.

9.2 Commissioning A1445 Relay Outstation (to Monitor Voltage-free Contacts)

1. Connect a Hand Held Test Tool to the 'LOOP IN +' and 'LOOP OUT -' terminals. Probe sockets are provided in the terminals to simplify this.
2. Ensure that the power supply to the outstation is switched OFF and that all inputs are in their quiescent state.
3. Switch on the Test Tool and select option 4 – 'IDENTIFY DETECTOR' from the menu. Observe that the Test Tool responds with the correct address and type required for the outstation. The outstation should also return an analogue value of 4.
4. Switch on the power supply to the outstation and select option 1 – 'SINGLE DETECTOR TEST' on the Test Tool. Enter '1' to select the new outstation address and enter the address returned in 3. Now set the outstation output bits to '000'. Observe that the outstation now returns an analogue value of 16.

5. If the outstation is monitoring an external power supply for a fault condition, introduce a fault on the power supply and observe that the Test Tool responds with an analogue value of 4. Remove the power supply fault and observe that the Test Tool shows an analogue value of 16.
6. If the outstation is not monitoring an external power supply fault operate the switch connected to the 'FAULT INPUT' and observe that the Test Tool shows an analogue value of 4. Reset the input and observe that the Test Tool shows an analogue value of 16.
7. Operate the switch connected to Input 2 and observe that the Test Tool responds with an analogue value of 48. Return the switch to its quiescent state and observe that the Test Tool shows an analogue value of 16.
8. Operate the switch connected to Input 1 and observe that the Test Tool responds with an analogue value of 64. Return the switch to its quiescent state and observe that the Test Tool shows an analogue value of 16.
9. Enter '2' on the Test Tool to set the outstation output bits. Enter '100' and observe that the BIT 0 relay activates and any external devices respond correctly.
10. Repeat step 9 setting the output bits to '010' and observe that the BIT 1 relay functions correctly.
11. Repeat step 9 setting the output bits to '001' and observe that the BIT 2 relay functions correctly.
12. The A1445 is now tested and can be connected to the loop.

9.3 Commissioning A1446 Sounder Outstation (to Monitor Voltage-free Contacts)

1. Follow steps 1 to 8 of the A1445 outstation commissioning procedure. All operations and responses should be identical.
2. Simulate an open circuit fault in the alarm wiring by removing the end of line resistor from the alarm circuit and observe that the Test Tool shows an analogue value of 4. Replace the end of line resistor; observe that the test tool shows an analogue value of 16.
3. Simulate a short circuit fault in the alarm wiring by connecting the two cores at the end of line point and observe that the Test Tool shows an analogue value of 4. Remove the short circuit and observe that the test tool shows an analogue value of 16.
4. Enter '2' on the Test Tool to set the outstation output bits. Enter '001' and observe that the 'BIT 2' relay activates and any external devices respond correctly.
5. Enter '2' on the Test Tool and reset the output bits to '000'. Observe that the auxiliary relay returns to its quiescent state.
6. Enter '2' on the Test Tool and set the output bits to '010'. Observe that the sounders on the alarm circuit repeatedly pulse on for 1 second and off for 1 second.
7. Reset the output bits to '000' and observe that the sounders silence.
8. Set the output bits to '100' and observe that the sounders operate continuously.
9. Reset the outstation output bits to '000' and observe that the sounders silence.
10. If the sounder controller is using a synchronisation signal from another outstation, energise this outstation and observe that the 'CLK IN' LED pulses on the sounder controller being commissioned. **NOTE: it is not necessary for the outstation generating the synchronisation signal to be connected to the loop or a Test Tool.**

11. Set the outstation output bits to '010'; observe that the sounders pulse in synchronisation with the 'CLK IN' LED. The sounders should be active when the LED is on.
12. Reset the outstation output bits to '000'.
13. The A1446 is now tested and can be connected to the loop.

9.4 Commissioning the A1444 and A1445 Outstations (for Zone Monitoring)

1. Connect a hand held Test Tool to the 'LOOP IN +' and 'LOOP OUT -' terminals. The loop terminals are provided with probe sockets to simplify this.
2. Ensure that the power supply to the outstation is turned OFF and that the field wiring is connected to Input 1 and Input 2 of the outstation. Each zone must be terminated with a 3k9 end of line resistor.
3. Switch on the Test Tool and select option 4 – 'IDENTIFY DETECTOR' from the menu. Observe that the Test Tool responds with the correct address and type required for the outstation. The Test Tool should also show an analogue value of 4.
4. Switch on the power supply to the outstation and select option 1 – 'SINGLE DETECTOR TEST' on the Test Tool. Enter '1' to select a new address and enter the address returned in step 3. Now set the outstation output bits to '000'. Observe that the Test Tool now shows an analogue value of 16.
5. Simulate an open circuit fault on Zone 1 by removing the end of line resistor and observe that the Test Tool shows an analogue value of 4. Replace the end of line resistor and observe that the Test Tool shows an analogue value of 16.
6. Simulate a short circuit fault on Zone 1 by connecting the two cores at the end of line point and observe that the Test Tool shows an analogue value of 4. Remove the short circuit and observe that the Test Tool shows an analogue value of 16.
7. Repeat steps 5 & 6 on Zone 2; observe that the Test Tool returns an analogue value of 4.
8. Operate the first detector on Zone 1 and observe that the Test Tool responds with an analogue value of 64.
9. Enter '2' on the Test Tool and set the outstation output bits to '100'. Reset the output bits to '000' and observe that the detector is reset after 10 seconds.
10. Repeat steps 8 and 9 for each detector on the zone.
11. Active each break glass unit on Zone 1 in turn and observe that the Test Tool responds with an analogue value of 64 for each one.
12. Operate each switch fitted to Zone 2 in turn and observe that the Test Tool shows an analogue value of 48 for each one.
13. The A1444 is now tested and can be connected to the loop.
14. The A1445 must now have its outputs commissioned by proceeding to step 9 of the section 9.2 above.

9.5 Connection of Outstations to the Loop

1. Connect the cabling from the previous device to the terminals labelled 'LOOP IN' observing the correct polarity.
2. Connect the cabling to the next device to the terminals labelled 'LOOP OUT' observing the correct polarity.

3. The outstation is now ready for system commissioning as described in the panel's Installation and Commissioning Manual.

9.6 Addressing

The A1440 range of outstations can be take any address on the loop in the range 1 to 126. The address is set using the binary switches ADD0 to ADD6 of switch S1 the PCB of the outstation. The switches are set according to the table below which shows the settings for each possible address available. Each binary 1 represents an address switch in the OFF position and each 0 a switch in the ON position. The digits in the table are ordered ADD0, ADD1, ADD2, ADD3, ADD4, ADD5, ADD6, ADD7 i.e. in the same order as the switches on the outstation PCB. Thus, for example, address 5 will have ADD1 and ADD 3 set to OFF and the other address switches will be ON.

9.6.1 Table Showing Address Switch Settings for CEL Outstations

Addr	Switches	Addr	Switches	Addr	Switches	Addr	Switches	Addr	Switches	Addr	Switches
1	1000000	22	0110100	43	1101010	64	0000001	85	1010101	106	0101011
2	0100000	23	1110100	44	0011010	65	1000001	86	0110101	107	1101011
3	1100000	24	0001100	45	1011010	66	0100001	87	1110101	108	0011011
4	0010000	25	1001100	46	0111010	67	1100001	88	0001101	109	1011011
5	1010000	26	0101100	47	1111010	68	0010001	89	1001101	110	0111011
6	0110000	27	1101100	48	0000110	69	1010001	90	0101101	111	1111011
7	1110000	28	0011100	49	1000110	70	0110001	91	1101101	112	0000111
8	0001000	29	1011100	50	0100110	71	1110001	92	0011101	113	1000111
9	1001000	30	0111100	51	1100110	72	0001001	93	1011101	114	0100111
10	0101000	31	1111100	52	0010110	73	1001001	94	0111101	115	1100111
11	1101000	32	0000010	53	1010110	74	0101001	95	1111101	116	0010111
12	0011000	33	1000010	54	0110110	75	1101001	96	0000011	117	1010111
13	1011000	34	0100010	55	1110110	76	0011001	97	1000011	118	0110111
14	0111000	35	1100010	56	0001110	77	1011001	98	0100011	119	1110111
15	1111000	36	0010010	57	1001110	78	0111001	99	1100011	120	0001111
16	0000100	37	1010010	58	0101110	79	1111001	100	0010011	121	1001111
17	1000100	38	0110010	59	1101110	80	0000101	101	1010011	122	0101111
18	0100100	39	1110010	60	0011110	81	1000101	102	0110011	123	1101111
19	1100100	40	0001010	61	1011110	82	0100101	103	1110011	124	0011111
20	0010100	41	1001010	62	0111110	83	1100101	104	0001011	125	1011111
21	1010100	42	0101010	63	1111110	84	0010101	105	1001011	126	0111111

0 = ON

1 = OFF

Appendices

i Outstation Specifications

A1444, A1445, A1446 Inputs

Supply Voltage: 17-25V loop derived
 Quiescent Current: 1.0mA loop derived + 0.5mA per active output(A1445/6 only)
 Input Terminals: Loop connections
 3 inputs for voltage free contacts
 External power supply
 Analogue Values: 64 - Input 1 operated
 48 - Input 2 operated
 4 - Input 3 operated (A1444 only)
 4 - Fault Input operated or local fault (A1445, A1446)
 16 - Quiescent condition

A1445

Local Power Supply Current: 2.5mA + 10mA per activated relay.
 Outputs: 3 sets of relay change over contacts
 Identification: Bit 0 pole, normally open, normally closed
 Bit 1 P, N/O, N/C
 Bit 2 P, N/O, N/C
 Rating: 8 Amps @ 30V DC

A1446

Local Power Supply Current: Quiescent condition: 10mA
 Full alarm load: 800mA
 Additional Input: Synchronisation input
 Outputs: Change-over relay rated at: 1 Amp @ 24V DC
 One monitored alarm circuit
 Rated at: 750mA
 Synchronisation output

A1447

Local Power Supply Current: Quiescent condition: 32mA + parent outstation current
 Short circuit both zones: 70mA + parent outstation current
 Zone Current: Fire condition: 14mA minimum

Low Voltage Directive 72/23/EEC – No voltage greater than 60V AC or 75 V DC must be connected to any terminal on any of the outstations covered in this document.

A1444/5/6 Output Functions

DEVICE TYPE	OUTSTATION TYPE	O/P BIT 0	O/P BIT 1	O/P BIT 2
0 SPARE	-	-	-	-
1 SOUNDER CONTROLLER	A1446	CONTINUOUS ALARMS	PULSED ALARMS	1 AMP CHANGE OVER CONTACT
2 I/O UNIT	A1445	PROGRAM	PROGRAM	PROGRAM
3 ION SMOKE	A1445	REMOTE LED	DEVICE TEST	DEVICE LED
4 ZONE MONITOR	A1444/5	ACTIVE ON RESET	PROGRAM	PROGRAM
5 OPTICAL SMOKE	A1445	REMOTE LED	DEVICE TEST	DEVICE LED
6 HEAT SENSOR	A1445	REMOTE LAMP	DEVICE TEST	DEVICE LED
7 PRIORITY DEVICE	A1445	REMOTE LED	DEVICE TEST	DEVICE LED
8 DO NOT USE	-	-	-	-
9 DO NOT USE	-	-	-	-
10 DO NOT USE	-	-	-	-
11 DO NOT USE	-	-	-	-
12 DO NOT USE	-	-	-	-
13 DO NOT USE	-	-	-	-
14 DO NOT USE	-	-	-	-
15 DO NOT USE	-	-	-	-

ii Termination Drawings

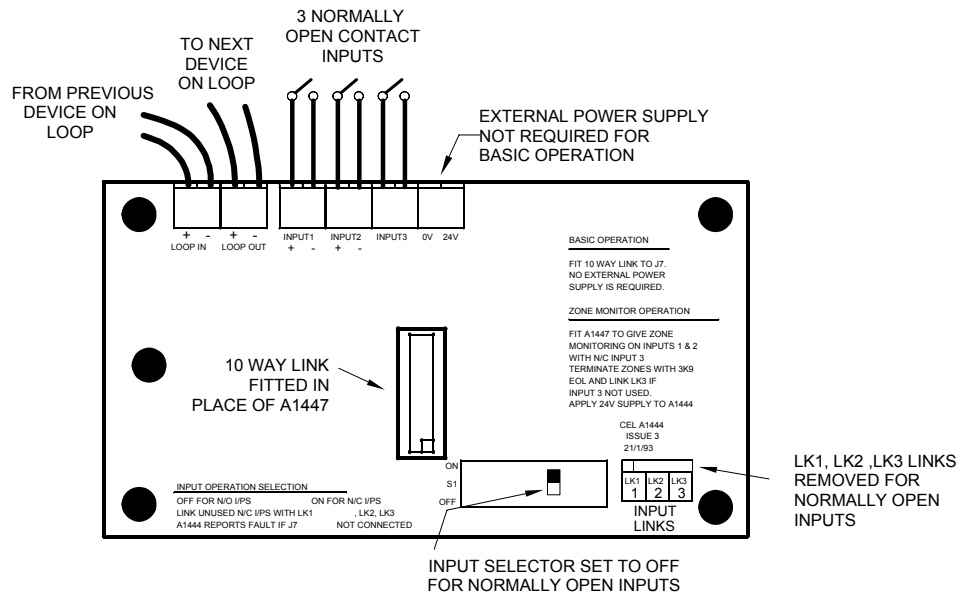

TERMINATION EXAMPLE 1:
A1444 MONITORING 3 NORMALLY OPEN INPUT SWITCHES

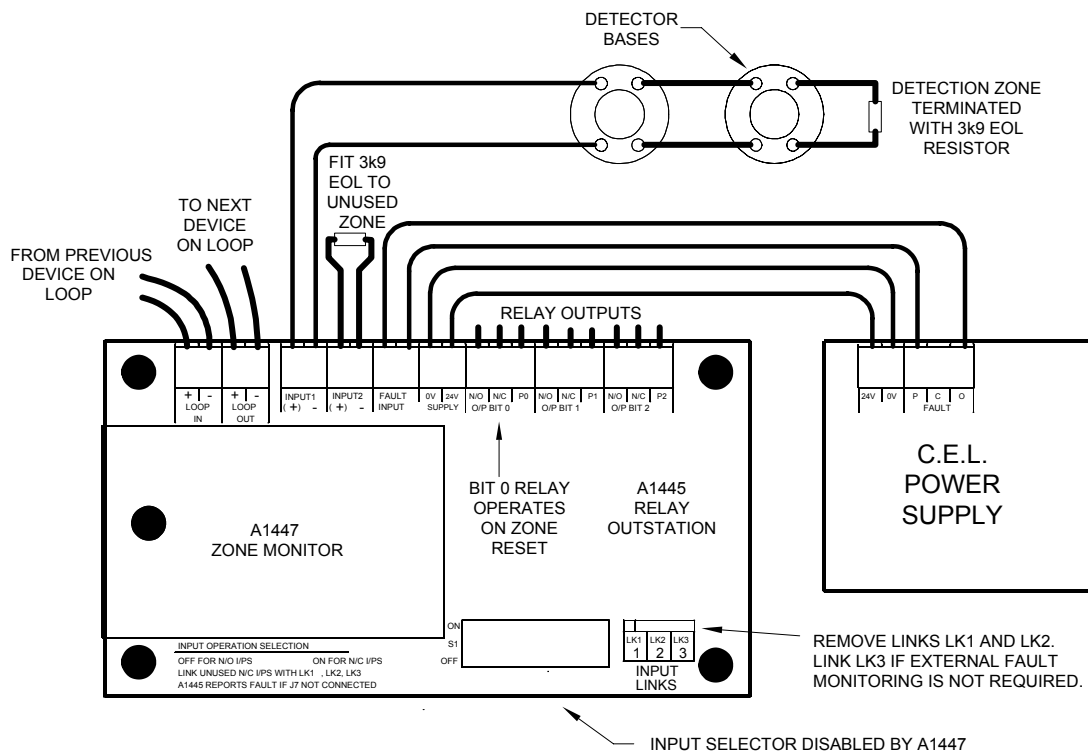

TERMINATION EXAMPLE 2:
A1445 RELAY OUTSTATION FITTED WITH A1447 ZONE MONITOR

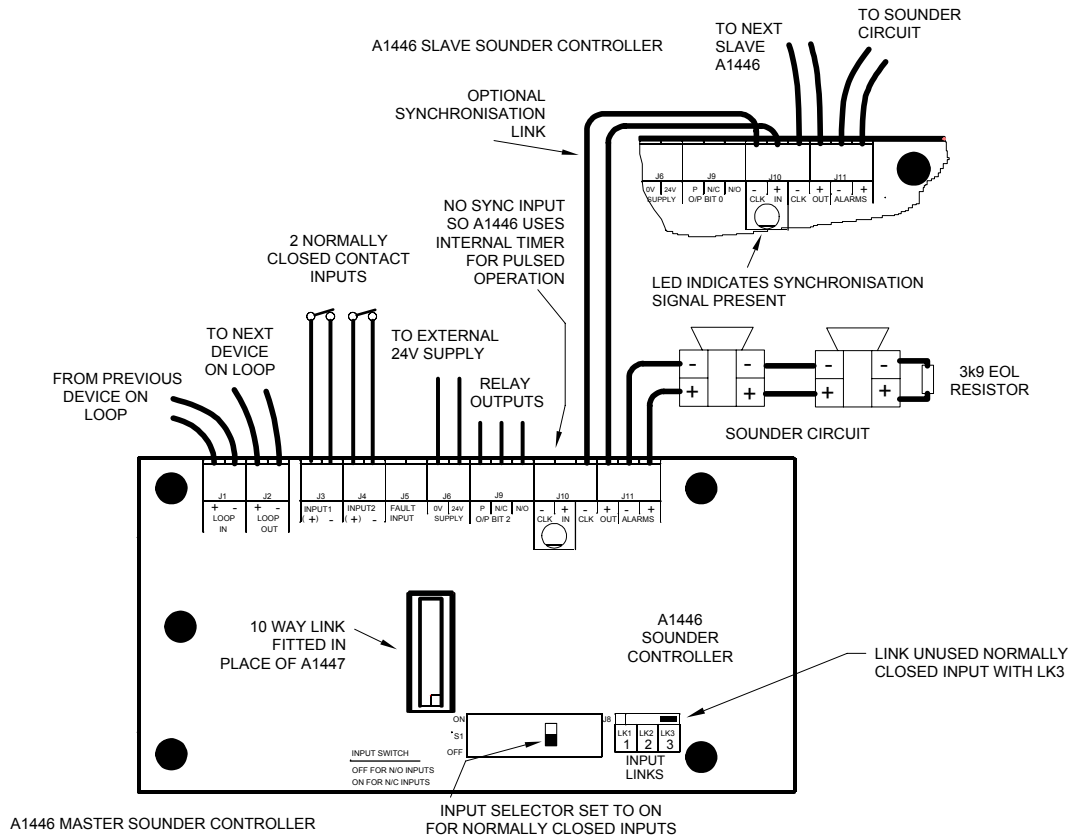

TERMINATION EXAMPLE 3:

A1446 SOUNDER CONTROLLER WITH SYNCHRONISED PULSED ALARM OPERATION MONITORING TWO NORMALLY CLOSED SWITCHES

A1444, A1445, A1446 AND A1447 OUTSTATION PHYSICAL DIMENSIONS

OUTSTATION	OVERALL SIZE	MOUNTING CENTRES
A1444	139MM x 76MM x 17MM	125MM x 63MM
A1445	143MM x 76MM x 18MM	125MM x 63MM
A1446	157MM x 79MM x 18MM	125MM x 63MM
A1447	PARENT OUTSTATION HEIGHT INCREASED TO 28MM, SIZE REMAINS UNCHANGED	MOUNTS ONTO PARENT OUTSTATION

iii Other Relevant Documentation

Application Guide for CEL Manufactured Outstations
Application Guide for Duplex 1-2 Loop Panels
Application Guide for Discovery 1-4 Loop Panels
Application Guide for Nexus 1-8 Loop Panels
Installation & Commissioning Manual for Duplex 1-2 Loop Panels
Installation & Commissioning Manual for Discovery 1-4 Loop Panels
Installation & Commissioning Manual for Nexus 1-8 Loop Panels
Battery & Loop Calculation Spreadsheets